

ESX.3cm

ESX Control Units

KEY FEATURES

- Control specially designed for use in harsh mobile applications
- Flexible programming in C, CODESYS V3.5 IEC61131-3, logi.CAD 3 IEC61131-3
- Suitable for safety-related applications according to IEC 61508:2010 or according to EN ISO 13849-1:2015
 - C, logi.CAD 3*: SIL 2 / PL d
 - CODESYS: SIL 1 / PL c

* Scheduled feature

TECHNICAL DATA

- TriCore TC 1798 32 bit, 300 MHz
- 288 kB SRAM internal, 8 MB SDRAM external
- 4 MB Flash internal
- 32 kB EEPROM
- 4 CAN interfaces (CAN 1 with wake-up function), 1 RS232 interface, 1 Ethernet interface
- 28 inputs (SENT support)
- 28 outputs

ACCESSORIES

- Component Deployment C, CODESYS V3.5, logi.CAD
- Compiler
- Mating Plug
- Integrated into STW's openSYDE software platform
- Debug Adapter
- Debugger
- Starter kit
- ESX-Testbox Adapter

Sensor-Technik Wiedemann GmbH

Am Bärenwald 6
87600 Kaufbeuren
Germany
+49 8341 9505-0
info.stw@wiedemann-group.com
www.stw-mm.com

BLOCK DIAGRAM

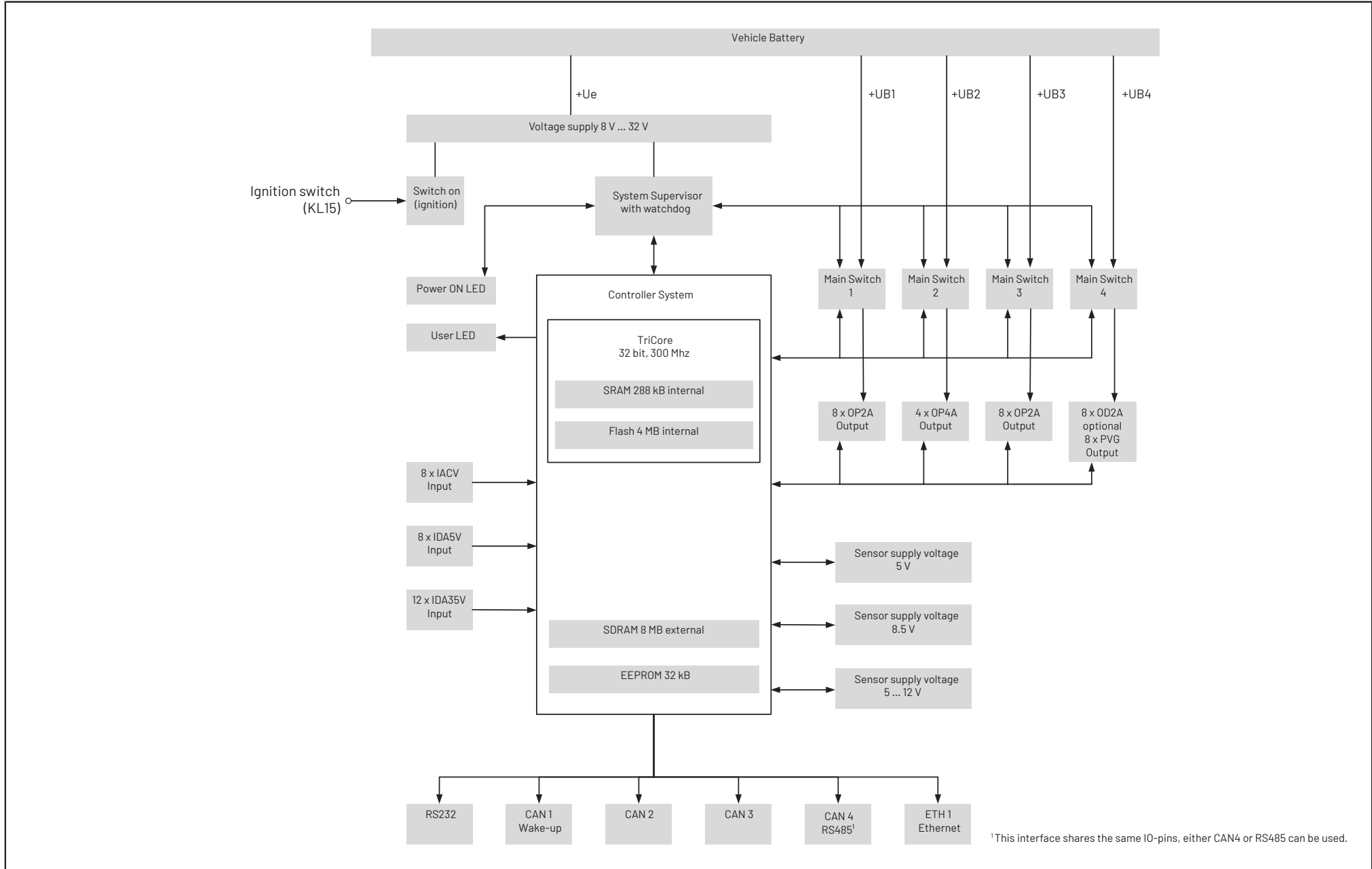

¹This interface shares the same IO-pins, either CAN4 or RS485 can be used.

TECHNICAL DATA

Processor and Memory

Type	Properties	Description
TriCore TC1798	32 bit, 300 MHz	<ul style="list-style-type: none"> External system supervisor with programmable watchdog 12 bit A/D converter for analog signal processing
SRAM	128 kB internal	On-chip RAM of the TriCore. This memory is used for system and application data. The space available for the customer application depends on the configuration of the system.
DSPRAM	128 kB internal	On-chip RAM of the TriCore without wait states. This memory mainly serves as system memory for BIOS stack and data, but also includes a heap for the customer application.
SDRAM	8 MB external	7.8 MB available for customer application in C 3 MB available for customer application in CODESYS
Flash	4 MB internal	3.75 MB available for customer application in C 2 MB available for customer application in CODESYS
EEPROM	32 kB	24 kB available for customer application typical endurance according to manufacturer: <ul style="list-style-type: none"> 1,000,000 erase/program cycles @ 25 °C 300,000 erase/program cycles @ 85 °C data retention > 20 years

Communication Interfaces

Type	Max. Quantity	Configuration
CAN	4	CAN 2.0 B, high-speed and low-speed, baud rate from 40 kbit/s to 1 Mbit/s
		CAN bus 1 with ECU wake-up feature
		CAN bus 4: Configurable as CAN- or RS485-interface
RS485	1	CAN 4 configured as RS485 interface: Baud rate up to 115 kbit/s, half-duplex communication, in parallel to CAN bus 4, can be used as RS485 or CAN bus
RS232	1	Baud rate up to 115 kbit/s
Ethernet	1	10/100 Mbit/s, hardware variant with additional connector

TECHNICAL DATA

Inputs

Type	Max. Quantity	Possible Configuration	Measurement	
Multi Functional Input IDA35V	12	Analog voltage	0 ... 35 V	
		Programmable pull-up resistor to +8.5V	1.1 kΩ	
		Programmable pull-down resistor to GND	1 kΩ	
		NAMUR sensor compatible		
		Digital	Low active	
			High active	
		Event driven	Events, reacts on falling or rising edge of the signal	
		Frequency	0.6 Hz ... 20 kHz	
		Incremental encoder interface	Change of position or angular change	
		Analog Input IACV	8	Analog voltage
Analog current	0 ... 24 mA			
Digital (voltage mode)	Low active			
	High active			
Event driven	Events, reacts on falling or rising edge of the signal			

Inputs

Type	Max. Quantity	Possible Configuration	Measurement
Multi Functional Input IDA5V	8	Analog voltage	0 ... 5 V
		Programmable pull-up resistor to +5V	6.8 kΩ
		Digital	Low active
			High active
		Event driven	Events, reacts on falling or rising edge of the signal
		Frequency	0.6 Hz ... 20 kHz
		SENT interface	



TECHNICAL DATA

Outputs (All Outputs are Short Circuit Protected)

Type	Max. Quantity	Possible Configuration	Range	Characteristics	Feature	Group
Digital/PWM Output OP4A	4	Digital PWM	0 ... 4 A	ON/OFF 0 ... 100 % Duty cycle resolution < 0.1 % PWM frequency 20 ... 1000 Hz	<ul style="list-style-type: none"> High-side switch Precise current measurement, accuracy is 2 % Supports current control mode Digital feedback, open load detection in OFF state Automated shutdown on overcurrent > 7.5 A ±20 % Combine several outputs for parallel operation up to 15 A 	Power supply group 2 +UB2: 4 outputs All outputs together can drive up to 15 A
Digital/PWM Output OP2A	16	Digital PWM	0 ... 2.5 A	ON/OFF 0 ... 100 % Duty cycle resolution < 0.1 % PWM frequency 20 ... 1000 Hz	<ul style="list-style-type: none"> High-side switch Precise current measurement, accuracy is 2 % Supports current control mode Digital feedback, open load detection in OFF state Automated shutdown on 	Power supply group 1 +UB1: 8 outputs Power supply group 3 +UB3: 8 outputs All outputs together can drive

Outputs (All Outputs are Short Circuit Protected)

Type	Max. Quantity	Possible Configuration	Range	Characteristics	Feature	Group
Digital Output OD2A	8	Digital PWM	0 ... 2.5 A	ON/OFF 0 ... 100 % Duty cycle resolution < 0.1 % PWM frequency 20 ... 1000 Hz	<ul style="list-style-type: none"> High-side switch Optimized for digital operation mode (ON/OFF) Current feedback, measurement accuracy is ±15.0 % (gain) ±100mA (offset) Output voltage feedback, voltage measurement with ±3 % Automated shutdown on overcurrent > 3.6 A ±20 % Combine several outputs for parallel operation up to 15 A 	Power supply group 4 +UB4: 8 outputs All outputs together can drive up to 15 A
optional: PVG Output		PVG				

TECHNICAL DATA

Outputs (All Outputs are Short Circuit Protected)

Type	Max. Quantity	Possible Configuration	Range	Characteristics	Feature	Group			
Sensor supply U _{ext}	3	program- mable	5 ... 12 V ±2.5 %	Program- mable output needs derating for output voltages U _{EXT} < 10 V: I _{MAX} = 0.9 / (13.6 - U _{EXT}) A	• The U _{ext} output voltage is stable also when the +UE input voltage is below the U _{ext} output voltage. E.g. it is possible to use U _{ext} = 12 V when +UE is at the min voltage +UE _{MIN} = 8 V	Supplied from ECU power pin +UE			
							Fixed voltage	8.5 V ±1.5 %	Maximal output current
							Fixed voltage	5 V ±1.0 %	I _{MAX} = 250 mA
Main Switch	4			ON/OFF	• Switches the four output groups • High-side switch • Current up to 15 A				

Mechanical Data

Component	Description	Value
Connector	KS1	Automotive 81 pins, matching plug: Tyco 1473244-1 and 1473244-3
	ETH1	4 pins M12 connector, D-coded
Indicators	2 LED, dual color (red/green or mixed colors)	1 for the state of the system, 1 freely programmable
Housing	Die-cast aluminum	GORE-TEX™-breathing filter for pressure equalization
Weight		About 1.3 kg (2 lb)
Degree of Protection	Variant without Ethernet connector	IP6k7 and IP6k9k
	Variant with Ethernet connector	IP6k7
Dimensions	Variant without Ethernet connector	217 mm x 138 mm x 51 mm
	Variant with Ethernet connector	217 mm x 152,5 mm x 51 mm
Operating temperature	Housing temperature	-40 ... +85 °C (-40 ... +185 °F)

TECHNICAL DATA

Power Supply

Component	Description	Range	
		Minimum Value	Maximum Value
DC voltage supply	Voltage at +UE ECU supply and +UB1..4 power supply	8 V DC	32 V DC
Current consumption	4x 15 A power pins fully loaded, short-term		60 A
- Stand-by	Sum of input currents at +UE and +UB1..4 ($U_{KL15} = 0$ V, ignition off)		< 1 mA
- ECU active	+UE supply current ($U_{KL15} > U_{KL15HIGH}$, no external load)		< 800 mA @ +UE = 12 V < 400 mA @ +UE = 24 V

TECHNICAL DRAWING

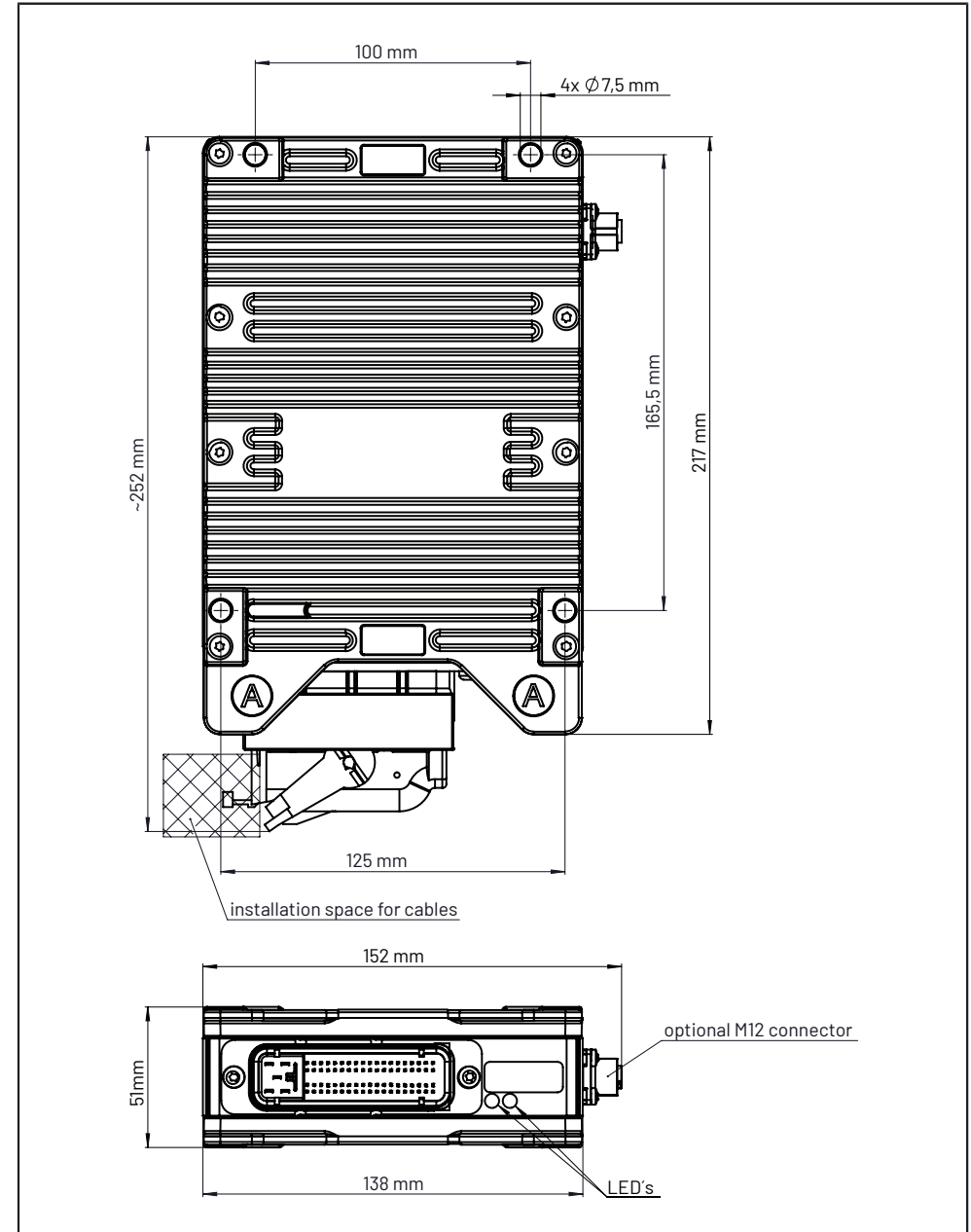

PIN ASSIGNMENT

Pin Assignment 81 Pin Connector:

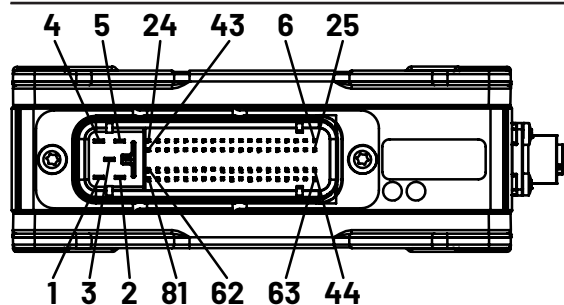

Connectors (male) of KS1

Pin Assignment 81 Pin Connector:

Pin	Functional Signal Name	BIOS Defines	Description
1	+UB4	X_SYS_RELAY_04 supply for output channel X_OUT_21..28	Power supply for the digital outputs of type OD2A (High-Side Digital 2.5 A)
2	GND	-	Ground of the ECU
3	+UB2	X_SYS_RELAY_02 supply for output channel X_OUT_09..12	Power supply of the PWM outputs of type OP4A (High-Side PWM 4 A)
4	+UB3	X_SYS_RELAY_03 supply for output channel X_OUT_13..20	Power supply of the PWM outputs of type OP2A (High-Side PWM 2.5 A)
5	+UB1	X_SYS_RELAY_01 supply for output channel X_OUT_01..08	Power supply of the PWM outputs of type OP2A (High-Side PWM 2.5 A)
6	+UE	-	Power supply of the ECU
7	CAN1_H	X_CAN_BUS_01	CAN bus 1 (high)
8	CAN3_H	X_CAN_BUS_03	CAN bus 3 (high)
9	IACV_2	X_IN_14	Analog input current 0 ... 24 mA / voltage 0 ... 12 V digital functionality with limited bandwidth
10	IDA35V_10	X_IN_10	Input digital, pull-up and pull-down, NAMUR, frequency, incremental input channel 4-A, analog input voltage 0 ... 35 V

PIN ASSIGNMENT

Pin Assignment 81 Pin Connector:

Pin	Functional Signal Name	BIOS Defines	Description	
11	IDA35V_6	X_IN_06	Input digital, pull-up and pull-down, NAMUR, frequency, analog input voltage 0 ... 35 V	
12	IDA35V_2	X_IN_02	Input digital, pull-up and pull-down, NAMUR, frequency, incremental input channel 1-B, analog input voltage 0 ... 35 V	
13	OP2A_5	X_OUT_05	Output High-Side PWM/digital 2.5A	
14	OP2A_6	X_OUT_06	Output High-Side PWM/digital 2.5A	
15	CAN1_H	X_CAN_BUS_01	CAN bus 1(high)	
16	IACV_5	X_IN_17	Analog input current 0 ... 24 mA / voltage 0 ... 12 V digital functionality with limited bandwidth	
17	OP4A_2	X_OUT_10	Output High-Side PWM/digital 4 A	
18	IDA5V_3	X_IN_23	Input digital, pull-up, SENT, frequency, analog input voltage 0 ... 5 V	
19	OP2A_15	X_OUT_19	Output High-Side PWM/digital 2.5 A	
20	OP2A_11	X_OUT_15	Output High-Side PWM/digital 2.5 A	
21	IDA5V_8	X_IN_28	Input digital, pull-up, SENT, frequency, analog input voltage 0 ... 5 V	
22	OD2A_8	X_OUT_28	Output High-Side Digital/PWM 2.5 A	Optional PVG
23	OD2A_4	X_OUT_24	Output High-Side Digital/PWM 2.5 A	Optional PVG
24	5Vext	X_SYS_SENSOR_SUP- PLY_03	Sensor supply voltage 5 V	

Pin Assignment 81 Pin Connector:

Pin	Functional Signal Name	BIOS Defines	Description
25	KL15	-	Ignition (KL15)
26	CAN1_L	X_CAN_BUS_01	CAN bus 1(low)
27	CAN3_L	X_CAN_BUS_03	CAN bus 3(low)
28	IACV_3	X_IN_15	Analog input current 0 ... 24 mA / voltage 0 ... 12 V digital functionality with limited bandwidth
29	IDA35V_11	X_IN_11	Input digital, pull-up and pull-down, NAMUR, frequency, incremental input channel 4-B, analog input voltage 0 ... 35 V
30	IDA35V_7	X_IN_07	Input digital, pull-up and pull-down, NAMUR, frequency, incremental input channel 3-A, analog input voltage 0 ... 35 V
31	IDA35V_3	X_IN_03	Input digital, pull-up and pull-down, NAMUR, frequency, analog input voltage 0 ... 35 V
32	OP2A_1	X_OUT_01	Output High-Side PWM/digital 2.5A
33	OP2A_2	X_OUT_02	Output High-Side PWM/digital 2.5A
34	CAN1_L	X_CAN_BUS_01	CAN bus 1(low)
35	IACV_6	X_IN_18	Analog input current 0 ... 24 mA / voltage 0 ... 12 V digital functionality with limited bandwidth
36	OP4A_3	X_OUT_11	Output High-Side PWM/digital 4 A
37	IDA5V_4	X_IN_24	Input digital, pull-up, SENT, frequency, analog input voltage 0 ... 5 V
38	OP2A_16	X_OUT_20	Output High-Side PWM/digital 2.5 A
39	OP2A_12	X_OUT_16	Output High-Side PWM/digital 2.5 A

PIN ASSIGNMENT

Pin Assignment 81 Pin Connector:

Pin	Functional Signal Name	BIOS Defines	Description
40	AGND	X_SYS_SENSOR_SUP-PLY_03	Analog GND of 5Vext (pin 24)
41	IDA5V_5	X_IN_25	Input digital, pull-up, SENT, frequency, analog input voltage 0 ... 5 V
42	OD2A_5	X_OUT_25	Output High-Side Digital/PWM 2.5 A Optional PVG
43	OD2A_1	X_OUT_21	Output High-Side Digital/PWM 2.5 A Optional PVG
44	RS232_TxD	X_SER_01	RS232 interface (TxD line)
45	CAN2_H	X_CAN_BUS_02	CAN bus 2 (high)
46	CAN4_H or RS485_A	X_CAN_BUS_04 or X_SER_02	CAN bus 4 (high) or RS485 interface (A-line, positive line)
47	AGND	X_SYS_SENSOR_SUP-PLY_01	Analog GND of 5-12Vext (pin 66)
48	IDA35V_12	X_IN_12	Input digital, pull-up and pull-down, NAMUR, frequency, analog input voltage 0 ... 35 V
49	IDA35V_8	X_IN_08	Input digital, pull-up and pull-down, NAMUR, frequency, incremental input channel 3-B, analog input voltage 0 ... 35 V
50	IDA35V_4	X_IN_04	Input digital, pull-up and pull-down, NAMUR, frequency, incremental input channel 2-A, analog input voltage 0 ... 35 V
51	OP2A_3	X_OUT_03	Output High-Side PWM/digital 2.5 A
52	OP2A_4	X_OUT_04	Output High-Side PWM/digital 2.5 A

Pin Assignment 81 Pin Connector:

Pin	Functional Signal Name	BIOS Defines	Description
53	8V5ext	X_SYS_SENSOR_SUP-PLY_02	Sensor supply voltage 8.5 V
54	IACV_7	X_IN_19	Analog input current 0 ... 24 mA / voltage 0 ... 12 V digital functionality with limited bandwidth
55	OP4A_4	X_OUT_12	Output High-Side PWM/digital 4 A
56	AGND	X_SYS_SENSOR_SUP-PLY_02	Analog GND of 8V5ext (pin 53)
57	IDA5V_1	X_IN_21	Input digital, pull-up, SENT, frequency, analog input voltage 0 ... 5 V
58	OP2A_13	X_OUT_17	Output High-Side PWM/digital 2.5 A
59	OP2A_9	X_OUT_13	Output High-Side PWM/digital 2.5 A
60	IDA5V_6	X_IN_26	Input digital, pull-up, SENT, frequency, analog input voltage 0 ... 5 V
61	OD2A_6	X_OUT_26	Output High-Side Digital/PWM 2.5 A Optional PVG
62	OD2A_2	X_OUT_22	Output High-Side Digital/PWM 2.5 A Optional PVG
63	RS232_RxD	X_SER_01	RS232 interface (RxD line)
64	CAN2_L	X_CAN_BUS_02	CAN bus 2 (low)
65	CAN4_L or RS485_B	X_CAN_BUS_04 or X_SER_02	CAN bus 4 (low) or RS485 interface (B-line, negative line)
66	5-12Vext	X_SYS_SENSOR_SUP-PLY_01	Programmable sensor supply voltage 5 ... 12 V

PIN ASSIGNMENT

Pin Assignment 81 Pin Connector:

Pin	Functional Signal Name	BIOS Defines	Description
67	IACV_1	X_IN_13	Analog input current 0 ... 24 mA / voltage 0 ... 12 V digital functionality with limited bandwidth
68	IDA35V_9	X_IN_09	Input digital, pull-up and pull-down, NAMUR, frequency, analog input voltage 0 ... 35 V
69	IDA35V_5	X_IN_05	Input digital, pull-up and pull-down, NAMUR, frequency, incremental input channel 2-B, analog input voltage 0 ... 35 V
70	IDA35V_1	X_IN_01	Input digital, pull-up and pull-down, NAMUR, frequency, incremental input channel 1-A, analog input voltage 0 ... 35 V
71	OP2A_7	X_OUT_07	Output High-Side PWM/digital 2.5 A
72	OP2A_8	X_OUT_08	Output High-Side PWM/digital 2.5 A
73	IACV_8	X_IN_20	Analog input current 0 ... 24 mA / voltage 0 ... 12 V digital functionality with limited bandwidth
74	IACV_4	X_IN_16	Analog input current 0 ... 24 mA / voltage 0 ... 12 V digital functionality with limited bandwidth
75	OP4A_1	X_OUT_09	Output High-Side PWM/digital 4 A
76	IDA5V_2	X_IN_22	Input digital, pull-up, SENT, frequency, analog input voltage 0 ... 5 V
77	OP2A_14	X_OUT_18	Output High-Side PWM/digital 2.5 A
78	OP2A_10	X_OUT_14	Output High-Side PWM/digital 2.5 A
79	IDA5V_7	X_IN_27	Input digital, pull-up, SENT, frequency, analog input voltage 0 ... 5 V

Pin Assignment 81 Pin Connector:

Pin	Functional Signal Name	BIOS Defines	Description	
80	OD2A_7	X_OUT_27	Output High-Side Digital/PWM 2.5 A	Optional PVG
81	OD2A_3	X_OUT_23	Output High-Side Digital/PWM 2.5 A	Optional PVG

PIN ASSIGNMENT

Pin Assignment 4 Pin M12 Connector:

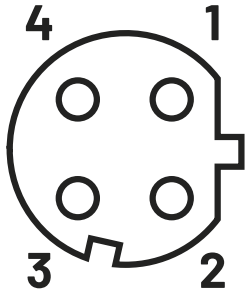

Pin assignment of the M12 connector of the Ethernet interface

Pin	Description	Coding
1	Tx+	D-coded
2	Rx+	
3	Tx-	
4	Rx-	

QUALIFICATION

Compliance Information

Standard	Description	Parameter
ISO/IEC 17050-1	Conformity	See Declaration of Conformity
KBA (Kraftfahrt-Bundesamt)	Certification This approved device can be used on any vehicle type with the following restrictions: All vehicle types with a 12 V respectively 24 V - electrical wiring and battery(-) at the body	According UN ECE Regulation No. 10
	RoHS Restriction of Hazardous Substances	

DETAILED QUALIFICATION

Electrical Safety

Standard	Test Description	Test Parameter
ISO 16750-2: 2012-11	Overvoltage	12 V: 60 min, Voltage supply = 18 V, T = 65 °C, 1 Cycle
ISO 16750-2: 2012-11	Overvoltage	24 V: 60 min, Voltage supply = 18 V, T = 65 °C, 1 Cycle
ISO 16750-2: 2012-11	Superimposed alternating voltage	12 V: Severity 4: Upp = 2 V, 10 min
ISO 16750-2: 2012-11	Superimposed alternating voltage	24 V: Severity 2: Upp = 4 V, 10 min
ISO 16750-2: 2012-11	Slow decrease and increase of supply voltage	Decrease and increase supply voltage with 0.5 V / min
ISO 16750-2: 2012-11	Momentary drop in supply voltage	12 V: Single voltage drop to 4.5 V
ISO 16750-2: 2012-11	Momentary drop in supply voltage	24 V: Single voltage drop to 9 V
ISO 16750-2: 2012-11	Reset behavior at voltage drop	12 V: Voltage drops in 5 % steps until 0 V, drop duration 10 s
ISO 16750-2: 2012-11	Reset behavior at voltage drop	24 V: Voltage drops in 5 % steps until 0 V, drop duration 10 s
ISO 16750-2: 2012-11	Starting profile switch-on hysteresis	12 V: Testlevel 4
ISO 16750-2: 2012-11	Starting profile switch-on hysteresis	24 V: Testlevel 3
ISO 16750-2: 2012-11	Load Dump	12 V Impulse a: Usmax = 70 V, 10 Pulses

Electrical Safety

Standard	Test Description	Test Parameter
ISO 16750-2: 2012-11	Load Dump	12 V Impulse b: Usmax = 70 V, 5 Pulses
ISO 16750-2: 2012-11	Load Dump	24 V Impulse a: Usmax = 70 V, 10 Pulses
ISO 16750-2: 2012-11	Load Dump	24 V Impulse b: Usmax = 70 V, 5 Pulses
ISO 16750-2: 2012-11	Reversed voltage case 2	Duration: 1 min
ISO 16750-2: 2012-11	Ground reference and supply offset	Max. offset (1 +/- 0.1) V
ISO 16750-2: 2012-11	Open circuit test - Single line interruption	Interruption 10 s +/- 1 s
ISO 16750-2: 2012-11	Open circuit test - Multiple line interruption	Interruption 10 s +/- 1 s
ISO 16750-2: 2012-11	Short circuits - signal lines	Connect every In- and Output to Usmax and GND for 1 min
ISO 16750-2: 2012-11	Short circuits - load lines	To load circuits duration: 5 min

DETAILED QUALIFICATION

Electromagnetic Compatibility (CE)

Standard	Test Description	Test Parameter
DIN EN 61000-6-3	Emission	Conducted Emission: 0.15 MHz to 30 MHz Radiated Emission: 30 MHz to 5000 MHz
DIN EN 61000-4-2: 2009-12	Electrostatic Discharge (ESD) direct	330 Ohm / 150 pF contact: +/- 2 kV / +/- 4 kV / +/- 6 kV air: +/- 2 kV / +/- 4 kV / +/- 8 kV / +/- 15 kV
DIN EN 61000-4-2: 2009-12	Electrostatic Discharge (ESD) indirect HCP	330 Ohm / 150 pF contact: +/- 2 kV / +/- 4 kV / +/- 6 kV
DIN EN 61000-4-2: 2009-12	Electrostatic Discharge (ESD) indirect VCP	330 Ohm / 150 pF contact: +/- 2 kV / +/- 4 kV / +/- 6 kV
DIN EN 61000-6-2: 2006-03	Limits and methods of measurement of radio disturbance; characteristics for the protection of receivers used on board vehicles	80 MHz to 2700 MHz, 10 V / m, 20 V / m
DIN EN 61000-4-4: 2013-04	Burst	1 kV & 3 kV (pos / neg)
DIN EN 61000-4-5: 2007-06	Surge	Symmetric: 0.5 kV 1 kV (Impedance: 2 Ohm + 18 µF) Dissymmetric 0.5 kV 1 kV 2 kV (impedance 12 Ohm + 9 µF)
DIN EN 61000-4-6: 2014	Voltage Dips	0.15 MHz to 80 MHz AM: 80 % / sinusoidal: 1000 Hz

Electromagnetic Compatibility (E1)

Standard	Test Description	Test Parameter
IEC/CISPR25: 2008/ECE R10	Emission	0.15 MHz to 2500 MHz
ISO 11452-2: 2004-11	Immunity	200 MHz bis 3000 MHz, 200 V / m
ISO 11452-4: 2011-12	Immunity	0.1 MHz bis 400 MHz, AM (1 kHz, 80 %)
ISO 11452-5: 2002-04	Immunity	0.01 MHz bis 1000 MHz, 200 V / m
ISO 7637-2: 2nd edition 2004+AMD1:2008	Emission	12 V: (pos) + 100 V, (neg) - 150 V
ISO 7637-2: 2nd edition 2004+AMD1:2008	Emission	24 V: (pos) + 200 V, (neg) - 600 V
ISO 7637-2: 2nd edition 2004+AMD1:2008	Road vehicles, electrical disturbance by conduction and coupling	Pulse 1 (12 V): - 100 V, 2 ms, 2 Ohm, 5000 pulses
ISO 7637-2: 2nd edition 2004+AMD1:2008	Road vehicles, electrical disturbance by conduction and coupling	Pulse 1 (24 V): - 600 V, 1 ms, 50 Ohm, 5000 pulses
ISO 7637-2: 2nd edition 2004+AMD1:2008	Road vehicles, electrical disturbance by conduction and coupling	Pulse 2a (12 V): + 50 V, 0.05 ms, 2 Ohm, 5000 pulses
ISO 7637-2: 2nd edition 2004+AMD1:2008	Road vehicles, electrical disturbance by conduction and coupling	Pulse 2a (24 V): + 50 V, 0.05 ms, 2 Ohm, 5000 pulses
ISO 7637-2: 2nd edition 2004+AMD1:2008	Road vehicles, electrical disturbance by conduction and coupling	Pulse 2b (12 V): + 10 V, 1 s, 10 pulses

DETAILED QUALIFICATION

Electromagnetic Compatibility (E1)

Standard	Test Description	Test Parameter
ISO 7637-2: 2nd edition 2004+AMD1:2008	Road vehicles, electrical disturbance by conduction and coupling	Pulse 2b (24 V): + 20 V, 1 s, 10 pulses
ISO 7637-2: 2nd edition 2004+AMD1:2008	Road vehicles, electrical disturbance by conduction and coupling	Pulse 3a (12 V): - 150 V, 150 ns, 50 Ohm, 1 h
ISO 7637-2: 2nd edition 2004+AMD1:2008	Road vehicles, electrical disturbance by conduction and coupling	Pulse 3a (24 V): - 200 V, 150 ns, 50 Ohm, 1 h
ISO 7637-2: 2nd edition 2004+AMD1:2008	Road vehicles, electrical disturbance by conduction and coupling	Pulse 3b (12 V): + 100 V, 150 ns, 50 Ohm, 1 h
ISO 7637-2: 2nd edition 2004+AMD1:2008	Road vehicles, electrical disturbance by conduction and coupling	Pulse 3b (24 V): + 200 V, 150 ns, 50 Ohm, 1 h
ISO 7637-2: 2nd edition 2004+AMD1:2008	Road vehicles, electrical disturbance by conduction and coupling	Pulse 4 (12 V): - 7 V, 1 pulse
ISO 7637-2: 2nd edition 2004+AMD1:2008	Road vehicles, electrical disturbance by conduction and coupling	Pulse 4 (24 V): - 16 V, 1 pulse
ISO 7637-2: 2nd edition 2004+AMD1:2008	Road vehicles, electrical disturbance by conduction and coupling	Puls a (12 V): - 60 V, 10 min
ISO 7637-2: 2nd edition 2004+AMD1:2008	Road vehicles, electrical disturbance by conduction and coupling	Puls a (24 V): - 80 V, 10 min

Electromagnetic Compatibility (E1)

Standard	Test Description	Test Parameter
ISO 7637-2: 2nd edition 2004+AMD1:2008	Road vehicles, electrical disturbance by conduction and coupling	Puls b (12 V): + 40 V, 10 min
ISO 7637-2: 2nd edition 2004+AMD1:2008	Road vehicles, electrical disturbance by conduction and coupling	Puls b (24 V): + 80 V, 10 min
IEC/CISPR25: 2008	Emission	30 kHz to 108 MHz
ISO 10605: 2008-07	Electrostatic Discharge (ESD)	330 Ohm / 330 pF, contact: +/- 2 kV, +/- 4 kV, +/- 6 kV, +/- 8 kV
ISO 10605: 2008-07	Electrostatic Discharge (ESD)	330 Ohm / 150 pF, +/- 6 kV, +/- 8 kV, +/- 15 kV, +/- 25 kV

DETAILED QUALIFICATION

Environmental Qualification

Standard	Test Description	Test Parameter
DIN EN 60068-2-64: 2009-04 ISO 16750-3: 2012-12	Environmental testing: Resonance search	5 Hz – 2000 Hz, 1 g, 1 oct / min
DIN EN 60068-2-64: 2009-04 ISO 16750-3: 2012-12	Environmental testing: Resonance search	5 Hz – 2000 Hz, 1 g, 1 oct / min
DIN EN 60068-2-27: 2010-02 ISO 16750-3: 2012-12	Environmental testing: Shock	50 g / 6 ms, half-sine wave, 10 shocks / axis
DIN EN 60068-2-31: 2009-04 ISO 16750-3: 2012-12	Environmental testing: Free fall	Drop height: 1 m
DIN EN 60068-2-6: 2008-10 ISO 16750-3: 2012-12	Environmental testing – Vibration (sinusoidal)	Frequency range: 10 Hz - 2000 Hz Acceleration: 5 g Sweep rate: 1 oct / min
DIN EN 60068-2-27: 2010-02 ISO 16750-3: 2012-12	Environmental testing: Shock	Pulse shape: half-sine Control strategy: single channel Acceleration: 50 g Pulse duration: 11 ms Number of tested axes: 3 Number of shocks: 3 positive, 3 negative per axis
DIN EN 60068-2-27: 2010-02	Environmental testing: Bump	Pulse shape: half-sine Control strategy: single channel Acceleration: 30 g Pulse duration: 6 ms Number of tested axes: 3 Number of shocks: 1000 positive, 1000 negative per axis
DIN EN 60068-2-1: 2008-01 ISO 16750-4: 2010-04	Environmental testing: Low temperature, storage	Tmin: - 40 °C Duration: 24 h

Environmental Qualification

Standard	Test Description	Test Parameter
DIN EN 60068-2-2: 2008-05 ISO 16750-4: 2010-04	Environmental testing: High temperature, storage	Tmax.: + 105 °C Duration: 48 h
ISO 16750-4: 2010-04	Environmental testing: Temperature step test	Tmax.: + 85 °C Tmin: - 40 °C Dwell time at each step: 1 hour (38 steps) Duration: 2 days
DIN EN 60068-2-14: 2010-04 ISO 16750-4: 2010-04	Environmental testing: Rapid change of temper- ature	Tmin: - 40 °C Tmax: + 85 °C Dwell time at Tmin / Tmax: 60 min Number of cycles: 100
DIN EN 60068-2-14: 2010-04 ISO 16750-4: 2010-04	Environmental testing: Temperature cycle with specified change rate	Tmin: - 40 °C Tmax: +85 °C Duration: 30 cycles a 480 min
DIN EN 60068-2-52: 1996-10 ISO 16750-4: 2010-04	Environmental testing: Salt spray corrosion test	
DIN EN 60068-2-11: 2000-02 ISO 16750-4: 2010-04	Environmental testing: Salt spray, leakage and function test	
DIN EN 60068-2-38: 2010-06	Environmental testing: Damp heat, steady state	Tmax: + 65 °C Tmin: - 10 °C Duration: 240 h (10 cycles a 24 h)
DIN EN 60068-2-78: 2014-02 ISO 16750-4: 2010-04	Environmental testing: Damp heat, steady state	Tmax: + 40 °C Relative humidity: 85 % RH Duration: 21 days
DIN EN 60068-2-30: 2006-06 ISO 16750-4: 2010-04	Environmental testing: Dewing test	Upper test temperature: + 80 °C Lower test temperature: + 25 °C Relative humidity: 98 % RH max / 55 % RH min

DETAILED QUALIFICATION

Environmental Qualification

Standard	Test Description	Test Parameter
		Number of test cycles: 5, 5.5 h per cycle Total test duration: 27.5 h
DIN EN 60068-2-60: 1996-09 ISO 16750-4: 2010-04	Corrosion test with flow of mixed gas	H2S - Concentration NO2 - Concentration Cl2 - Concentration SO2 - Concentration
ISO 20653: 2013-02	IP Protection classes	IP6KX IPX5
ISO 16750-5: 2010-04	Chemical resistance	Diesel Coffee Whitener Biodiesel Runway deicer Kerosene Coffeine / Sugar Engine oil Differential oil Denatured alcohol Methanol Urea Cosmetic products Acetone Hydraulic fluid
DIN EN 60068-2-14: 2010-04	Life test (Weibull)	- 40 °C to + 125 °C, dwell time: 1 h, cycle time: 2 h, cycles: 290, test time: 580 h (ca 24 days)