

SMX.dms-a

Strain sensors

KEY FEATURES

- Strain sensor for measurement of deflections, e.g. of metal arms, in various directions, which allows an indirect recording of forces, weights or vibrations
- Optimized assembly technology for easy commissioning directly at the production line
- Optionally also available pre-mounted on carrier plate
- Robust design for harsh environments
- Easy to service as configuration parameter can be transferred to the replacement sensor
- Integrated in STW software toolchain openSYDE
- With ECE type approval
- Economically available in small quantities

TECHNICAL DATA

- Measurement span adjustable in steps from 120 $\mu\text{m}/\text{m}$ up to 2000 $\mu\text{m}/\text{m}$, with configurable offset and measurement range within \pm of the selected span
- Operating temperature range $-40 \dots +85 \text{ }^\circ\text{C}$ ($-40 \dots +185 \text{ }^\circ\text{F}$)
- CAN interface, current loop interface (optional)
- High signal to noise ratio (SNR) of output signals
- Protection class IP6K5 / IPX7 / IPX9K (when installed or pre-mounted on carrier plate)

Sensor-Technik Wiedemann GmbH

Am Bärenwald 6
87600 Kaufbeuren
+49 8341 9505-0
info.stw@wiedemann-group.com
www.stw-mm.com

TECHNICAL DATA

Sensor

Parameter	Value
Measurement span	Adjustable in steps from 120 µm/m up to 2000 µm/m
Measurement range	Between ± of selected measurement span with configurable offset
Overload	50.000 µm/m
Accuracy at room temperature ^{1) 2)}	±1.0 %FS @ +25 °C (+77 °F)
Accuracy over operating temperature ^{1) 2)}	±1.5 %FS @ -10 ... +50 °C (+14 ... +122 °F)
	±2.5 %FS @ -40 ... < -10 °C (-40 ... < +14 °F)
	±2.0 %FS @ > +50 ... +85 °C (> +122 ... +185 °F)
Output signals	CAN bus 2.0B with output of either ADC raw data or elongation (µm/m), Baud rate: 100 ... 1000 kBit/s, protocol: CAN-STW-Standard, optional: 4 ... 20 mA (3-wire)
Bandwidth (-3 dB)	200 Hz
Operating temperature range ¹⁾	-40 ... +85 °C (-40 ... +185 °F)
Storage temperature	-40 ... +100 °C (-40 ... +212 °F)

Note: adhesive not included

Power Supply

Parameter	Value
Supply voltage	8 ... 32 V DC
Current consumption	< 150 mA (typ. < 100 mA)

¹⁾ Temperature response of strain gauge adapted to ferritic steel with a temperature coefficient of $10.8 \cdot 10^{-6} \text{ 1/K}$

²⁾ At measurement span 2000 µm/m

³⁾ Maximum cable length: 30 m

Housing

Item	Property
Electrical connection	1.35 m / 3 m cable without connector, connectors and other lengths on request ³⁾
Weight	approx. 80 g (without carrier plate and cable)
Material	Aluminum, anodized
Protection class	IP6K5 / IPX7 / IPX9K (when installed or pre-mounted on carrier plate)

Functional Safety

Standard	Description
EN ISO 13849-1:2015	PL b / Category B MTTF _D = 485.36 years
MTTF (by using SN 29500)	242.68 years

Operating area for current output

Parameter	Value
Output signal	4 ... 20 mA, load resistance to GND
Load resistance	100 ... 500 Ω (specified range)
Permitted range	$R_{Lmin} = 42.918 \text{ Ω/V} \cdot V_{CC} - 995.857 \text{ Ω}$
	$R_{Lmax} = 42.918 \text{ Ω/V} \cdot V_{CC} - 167.818 \text{ Ω}$

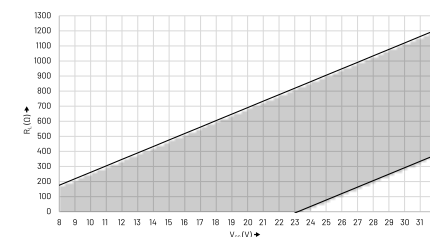

TECHNICAL DRAWING

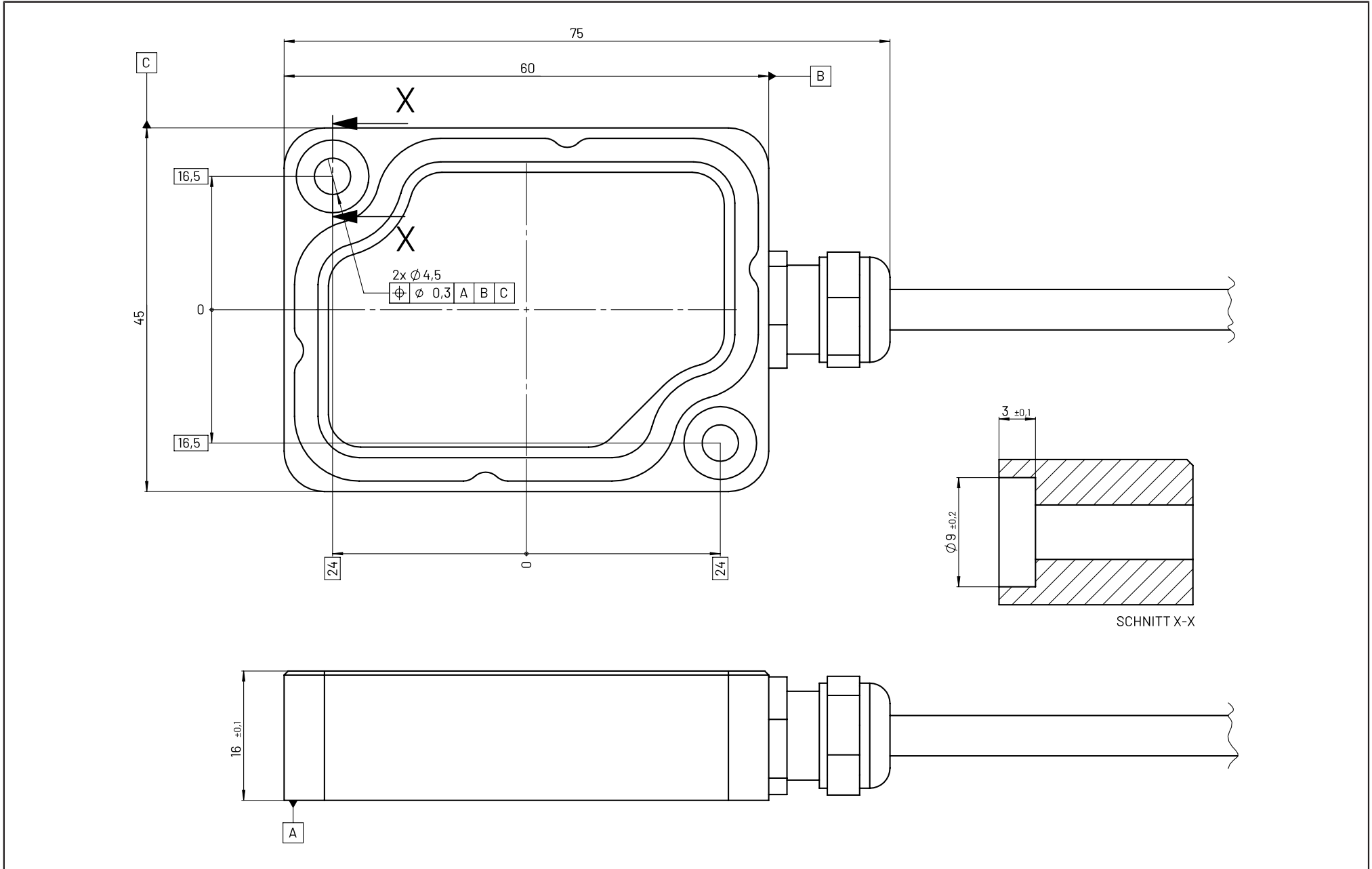

TECHNICAL DRAWING

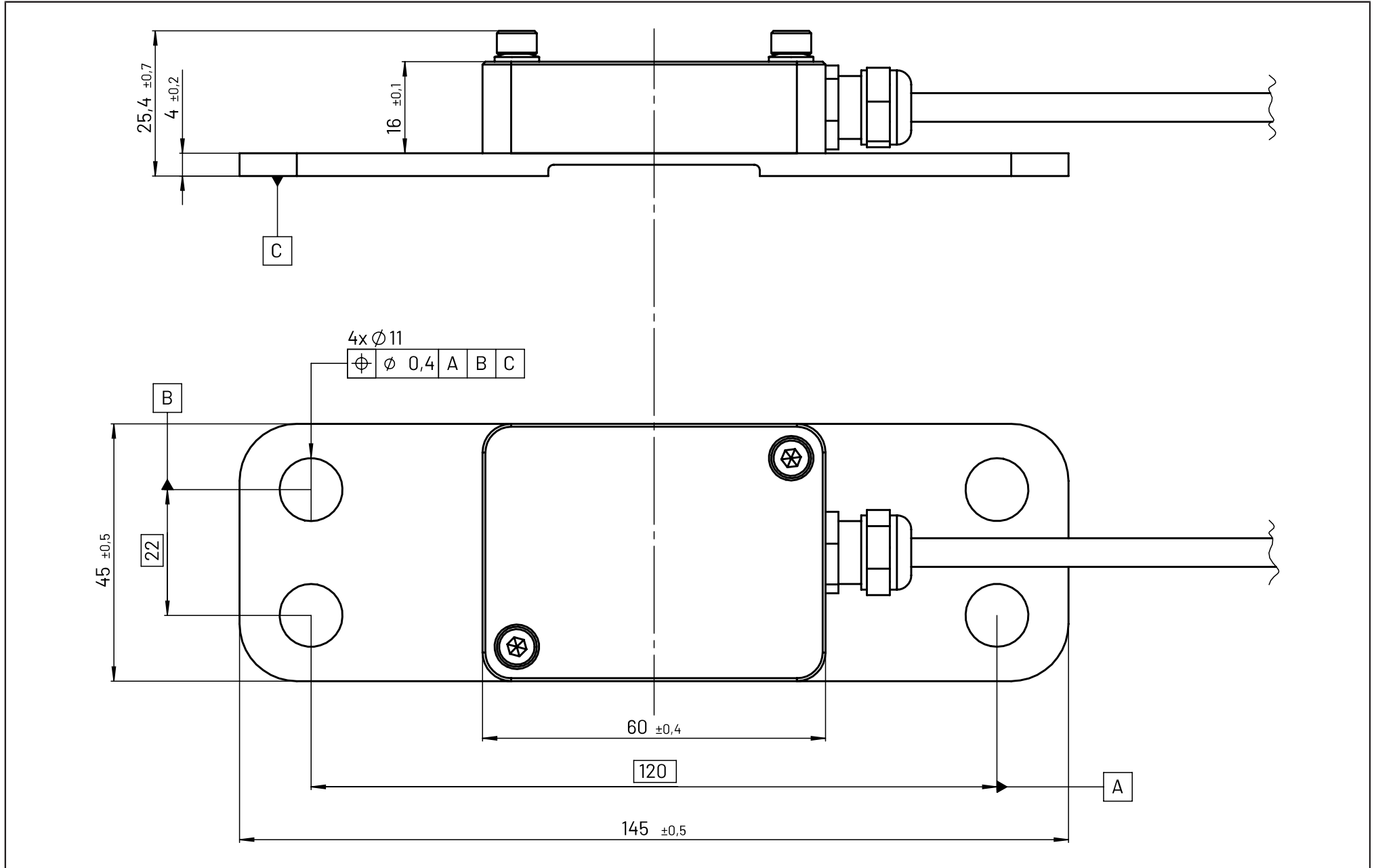

TECHNICAL DRAWING

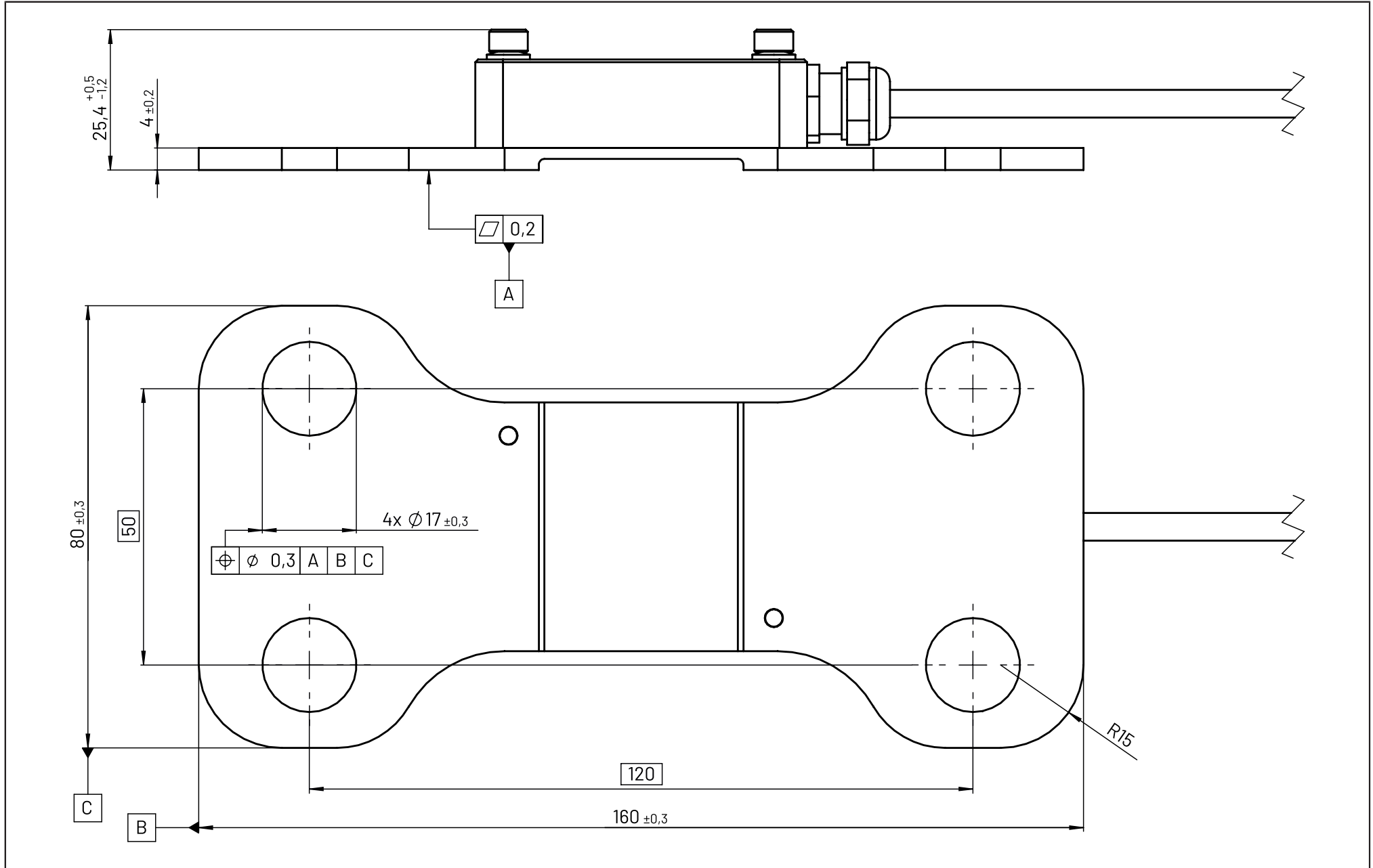

PIN ASSIGNMENT

Cable Connection ⁴⁾

Wire Color	Signal
Orange (OG)	CAN_H
Green (GN)	CAN_L
Red (RD)	V _{CC} , 8 ... 32 V DC
Black (BK)	GND
Yellow (YE)	Current output, 4 ... 20 mA

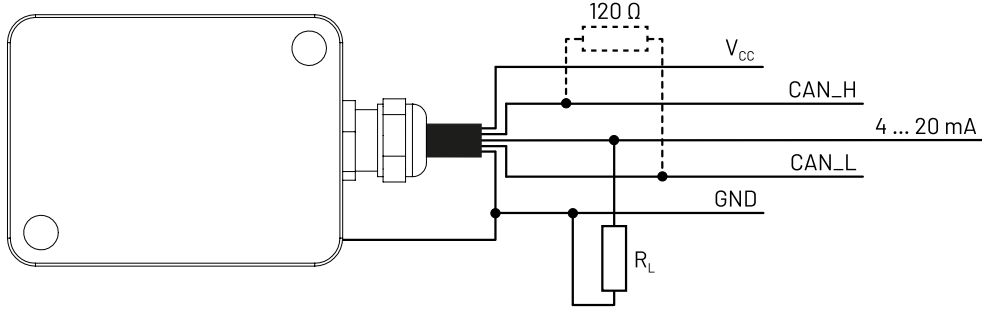

QUALIFICATION

Compliance Information

Standard	Description	Parameter
ISO/IEC 17050-1	Conformity	
KBA (Kraftfahrt-Bundesamt)	Certification	According UN ECE Regulation No. 10

⁴⁾ Standard shipment with open cable end (shielded cable) and without connector

DETAILED QUALIFICATION

EMC industrial (CE)

Standard	Test Description	Test Parameter
EN 61000-6-3:2007 +A1:2011 EN 55016-2-1:2014 +A1:2017	Emissions (residential, commercial and light-industrial environments)	150 kHz to 30 MHz conducted
EN 61000-6-3:2007 +A1:2011 EN 12895:2015 EN 55016-2-3:2017	Emissions (residential, commercial and light-industrial environments)	Distance 10 meters, Antenna height 3 m, 30 MHz to 1000 MHz,
EN 61326-1:2013 EN 61000-6-2:2005 EN 61000-4-2	Immunity for industrial environments - electrostatic discharge immunity test	330 Ω / 150 pF, Contact discharge \pm 15 kV Air discharge \pm 2/4/8/15/25 kV
EN 61326-1:2013 EN 61000-6-2:2005 EN 61000-4-3:2006 +A1:2008 +A2:2010	Immunity for industrial environments - radiated, radio-frequency, electromagnetic field immunity test	27 MHz to 80 MHz -> 36 V/m 80 MHz to 1.0 GHz -> 20 V/m 1.0 GHz to 6.0 GHz -> 10 V/m 3 m, horizontal and vertical AM 80 %, 1 kHz
EN 61326-1:2013 EN 61000-6-2:2005 EN 61000-4-4:2012	Immunity for industrial environments - burst (electrical fast transient/burst immunity test)	Supply lines \pm 2 kV, data lines \pm 1 kV, waveform: 5/50 ns tr/th, repetition frequency 5 kHz
EN 61326-1:2013 EN 61000-6-2:2005 EN 61000-4-5:2014 +A1:2017	Immunity for industrial environments - surge immunity test	\pm 0,5/1 kV Supply lines \pm 0,5/1/2 kV unbalanced (line against housing)
EN 61326-1:2013 EN 61000-6-2:2005 EN 61000-4-6:2014	Immunity for industrial environments - conducted immunity (immunity to conducted disturbances, induced by radio-frequency fields)	150 kHz to 80 MHz, 10 V, 80 % AM, sinus at 1 kHz 150 Ω source impedance

EMC industrial (CE)

Standard	Test Description	Test Parameter
EN 12895:2015 EN 61000-4-8:2010	Protection against static magnetic field	Frequency: 0 Hz Duration: 3 sec Field strength: 1000 A/m
EN 61000-6-2:2005 EN 12895:2015 EN 61000-4-8:2010	Protection against dynamic magnetic field	Frequency: 50 Hz, 60 Hz Duration: 3 sec Field strength: 30 A/m

EMC automotive

Standard	Test Description	Test Parameter
UN ECE R10	Radiated emissions from components - ALSE method (RE test)	30 MHz to 1000 MHz
UN ECE R10 ISO 7637-2:2004	Voltage transient emissions test (CTE Test)	12 V: < +75/-100 V 24 V: < +150/-450 V
UN ECE R10 ISO 7637-2:2004	Electrical transient conduction along supply lines only (12 V/24 V systems) level 3 (TSUP test)	Pulse 1 (12 V) 75 V, 5000 pulses Pulse 1 (24 V) 450 V, 5000 pulses Pulse 2a (12 V + 24 V) 37 V, 5000 pulses Pulse 2b (12 V), 10 V, 10 pulses Pulse 2b (24 V), 20 V, 10 pulses Pulse 3a (12 V), -112 V, 1 hr Pulse 3a (24 V), -150 V, 1 hr Pulse 3b (12 V), +75 V, 1 hr Pulse 3b (24 V), +150 V, 1 hr Pulse 4 (12 V), -6 V, 1 pulses Pulse 4 (24 V), -12 V, 1 pulses
UN ECE R10 ISO 11452-2:2004 ISO 11452-5:2002	Immunity to electromagnetic energy	80 MHz - 2000 MHz ALSE 30 V/m Stripline 60 V/m

DETAILED QUALIFICATION

Climatic and mechanical tests

Standard	Test Description	Test Parameter
ISO 16750-4:2010	Tests at constant temperature: Low temperature - storage	- 40°C for 24 hrs
ISO 16750-4:2010	Tests at constant temperature: High temperature - storage	85°C for 48 hrs
ISO 16750-4:2010	Temperature step test	20°C to Tmin to Tmax, 5°C steps; Duration: 16 hrs (-40°C to +85°C) Perform functional tests (OM 3.2) when DUT has reached the new temperature
ISO 16750-3:2012 EN 60068-2-32:1993	Free fall	3 devices, 2 falls every device on the opposite side of the housing. drop height: 1 m to concrete ground or steel plate - 1m, 6 Achsen
ISO 16750-4:2010	Tests at constant temperature: Low temperature - operation	- 40°C for 24 hrs
ISO 16750-4:2010	Tests at constant temperature: High temperature - operation	85°C for 96 hrs max. output current, max. power
ISO 16750-4:2010	Temperature cycling test - Rapid change of Temperature	acc. to IEC 60068-2-14, Test Na 100 cycles, -40°C to 85°C Transfer time < 5 sec. Dwell time: 60 min. Duration: 8 days 8 hrs
ISO 16750-4:2010	Temperature cycling test	acc to DIN EN 60068-2-14, Test Nb -40°C...85°C

Climatic and mechanical tests

Standard	Test Description	Test Parameter
		240 cycles Dwell time: 0,5h
ISO 16750-4:2010	Salt spray test - Leakage and function	acc to IEC60068-2-11, Ka; 8h salt spray and 16h without spray, minimum 6 cycles á 24 hrs
ISO 16750-4:2010	Humid heat cyclic - Test 2: Composite temperature / humidity cyclic test	acc to IEC60068-2-38, -Z/AD 10 cycles, upper temperature +65°C 93% r.H. 5 cycles with frost phase (-10°C); Duration: 11 days OM 3.2 when the maximum cycle temperature is reached;
DIN EN 60068-2-6:2008-10	Vibration (sinusoidal)	10 Hz...2000 Hz, 1oct/min, 10g, 10 cycles, bidirectional Duration: 0.5 days
ISO 16750-3:2012-12 DIN EN 60068-2-27:2010-02	Shock	Half Sine Acceleration: 50 g Time: 11 ms 3 Shocks/axis Directions: 6 Duration: 0.5 days
ISO 16750-3:2012-12 DIN EN 60068-2-27:2010-02	Bump	Acceleration: 30 g Time: 6 ms sinus 1000 Shocks/axis 500 Schocks each direction / Directions: 6 Duration 1.5 days
ISO 16750-4:2010 DIN EN 60068-2-52:2018-08	Salt spray test - Corrosion test	Severity 4 Duration: 14 d

DETAILED QUALIFICATION

Climatic and mechanical tests

Standard	Test Description	Test Parameter
ISO 16750-4:2010 IEC60068-2-60, Test Ke	Corrosion test with flow of mixed gas	Method 4; Duration: 21 days SO ₂ , H ₂ S, NO ₂ , CL ₂ 14
DIN EN 60529:2000-09 ISO 20653:2013-02	IP Protection	IP6K5 / IPX7 / IPX9K
According to ISO 16750-5:2010	Chemical resistance	Exposure time 24 h, Exposure condition.20°C, 85% relative humidity, Gasoline, diesel fuel, STILL Highly effective quick cleaning spray, Spiritus Exposure time 24 h Exposure. 85°C, 85% rel. humidity STILL high load chains adhesive lubricant, Hydraulic oil, biological hydraulic oil, Coca Cola, cement, fertilizer, skin care products, sun milk, battery acid, radiator antifreeze, window cleaner, washing lye, airport de-icing agent
ISO 16750-1:2018 Annex B	Life-time (Temperature cycling test - Rapid change of Temperature) Weibull	Weibull Test duration: 51 days Min. temperature: -40°C Max. temperature: 120°C Holding time: 45 min Cycles: 792 Operating status: 1.1
STW WN (26688)	Life-time (STW - Intern)	Test duration: 52 days Test temperature: 65°C

Climatic and mechanical tests

Standard	Test Description	Test Parameter
ISO 16750-4:2010-04 DIN EN 60068-2-78 (VDE 0468-2-78):2014-02	Damp heat, steady-state test	Operating status: 2.2 Operating state: A +40°C and 93% r.H. OM: 2.1 for 20 days 23 hrs OM: 3.2 for the last hour Duration: 21 days