

ESX.4cs-gw

ESX Control units

KEY FEATURES

- Control specially designed for use in harsh mobile applications
- Flexible programming in C or IEC61131-3 (logi.CAD)
- Designed as a communication node between the different networks in mobile work machines
- Suitable for safety-related applications up to SIL2 according to IEC 61508:2010 or PL d according to EN ISO 13849-1:2015

TECHNICAL DATA

- Aurix TC299 Multicore 32 bit, 300 MHz
- Internal: 2 MB RAM, 8 MB Flash
- External: 16 MB Flash
- 32 kB EEPROM
- 6 CAN interfaces, 1 RS232 interface, up to 5 Ethernet interfaces and 1 LIN
- 12 inputs (SENT support)
- 4 outputs
- 2 sensor supplies

ACCESSORIES

- Debug variants of the controller
- Debugger
- Compiler
- Starter kit
- Component Deployment C, logi.CAD IEC61131-3
- Mating Plug
- Integrated in STW Software Toolchain openSYDE

Sensor-Technik Wiedemann GmbH

Am Bärenwald 6
87600 Kaufbeuren
+49 8341 9505-0
info.stw@wiedemann-group.com
www.stw-mm.com

BLOCK DIAGRAM

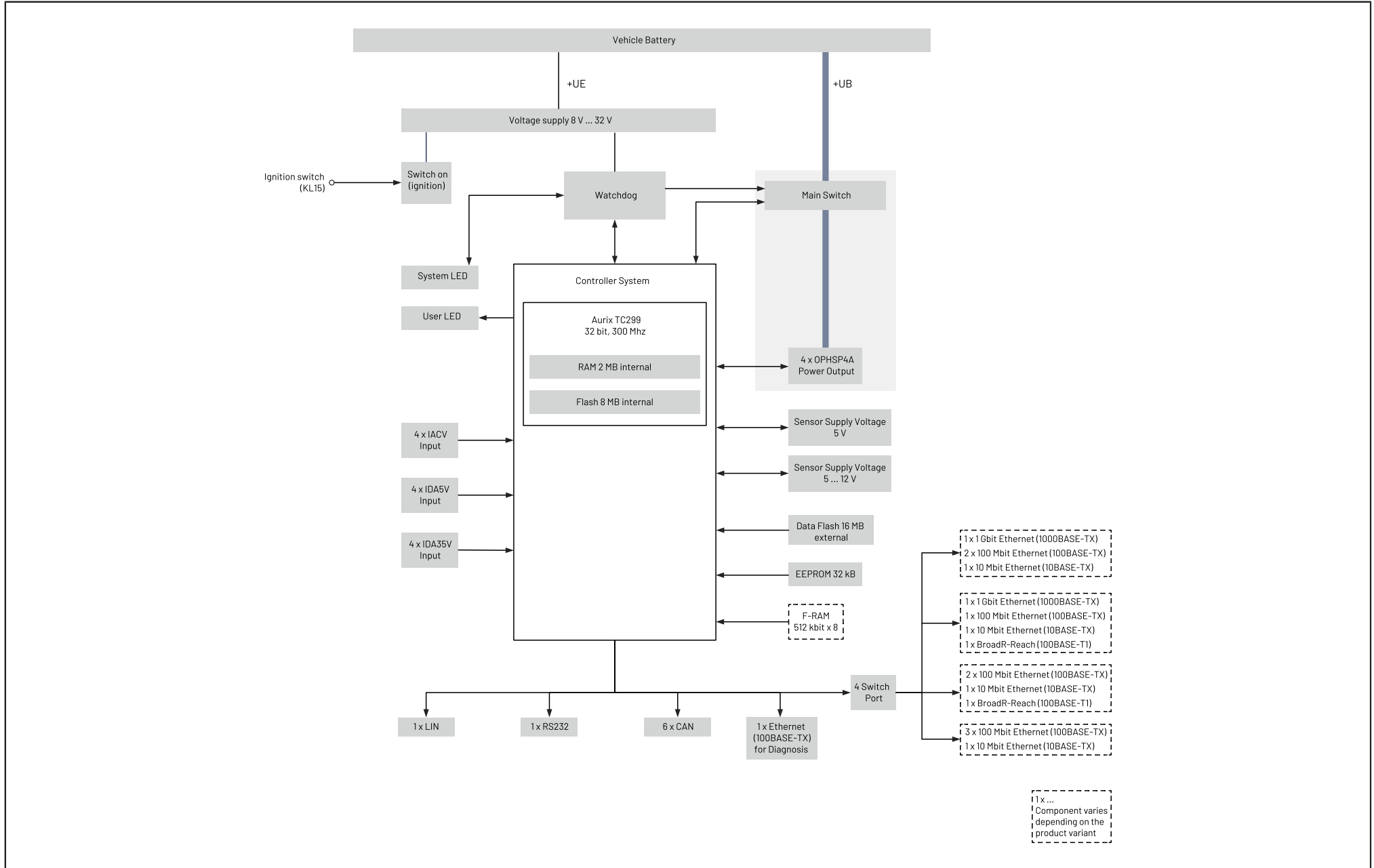

Variants

Variant features of the ESX.4cs-gw

Variant	Analog Input IACV	Multifunctional Input IDA5V	Multifunctional Input IDA35V	Digital/ PWM High Side Output OPHSP4A	Available CAN Interfaces	RS232	Up to 100 Mbit Ethernet	1 Gbit Ethernet over M12 connector	100 Mbit Ethernet for diagnosis	FRAM
Variant 1	4	4	4	4	6	1	4	-	1	1
Variant 2	4	4	4	4	6 CAN bus 1 with wake-up functionality, and with isolated CAN bus 4	1	3	1	1	-
Variant 3	4	4	4	4	6 (with isolated CAN bus 4)	1	3	1	1	-
Variant 4	4	4	4	4	6	1	4	-	1	-
Variant 5	4	4	4*	4	6	1	3	1	1	-

*) Customized threshold value

TECHNICAL DATA

Processor and Memory

Type	Properties	Features
Aurix TC299	32 bit, multi-core processor, up to 300 MHz	<ul style="list-style-type: none"> External system supervisor with window watchdog 12 bit A/D converter for analog signal processing
Flash	8 MB	7.75 MB available for customer application
Data Flash	16 MB	External Data Flash
RAM	2 MB	On-chip RAM This memory mainly serves as system memory for BIOS stack and data, but also includes a heap for the customer application.
EEPROM (non volatile memory)	32 kB	Available for customer application. Data Retention: <ul style="list-style-type: none"> 50 years at 125 °C 100 years at 25 °C Typical endurance according to manufacturer: <ul style="list-style-type: none"> 4 million Write cycles at 25 °C 1.2 million Write cycles at 85 °C 600 k Write cycles at 125 °C 400 k Write cycles at 145 °C
FRAM	4 Mbit (512 kbit x 8 bit)	External (optional, in variant 1 available) High endurance 100 trillion read/write cycles

TECHNICAL DATA

Communication Interfaces

Type	Maximal available counts	Configuration
CAN	6	CAN 2.0 B, high-speed and low-speed, baud rate from 40 kbit/s to 1 Mbit/s Optional CAN bus 1: Wake-up functionality Optional CAN bus 4: isolated
Ethernet	5	<ul style="list-style-type: none">• 1 x 100 Mbit/s Ethernet for diagnostic monitoring• 1 x 4 port Ethernet switch:<ul style="list-style-type: none">◦ 1 x 10 Mbit/s Ethernet◦ 2 ... 3 x 100 Mbit/s Ethernet (optional 1 x configurable for BroadR-Reach)◦ Optional available: 1 x 1 Gbit/s Ethernet over M12 connector
RS232	1	Baud rate up to 115 kbit/s

TECHNICAL DATA

Inputs

Type	Maximal available counts	Possible configuration	Measurement
Multifunctional input IDA35V	4	Analog voltage	0 ... 35 V
		Programmable pull-up resistor	1.1 kΩ to +8.5 V
		Programmable pull-down resistor	1 kΩ to GND
		NAMUR sensor	NAMUR sensor compatible
		Digital	Active high Active low
		Edge Evaluation	Events, reacts on falling or rising edge of the signal
		Frequency	0.6 Hz ... 20 kHz
		Incremental encoder interface	Change of position or angular change
Analog input IACV	4	Analog voltage	0 ... 12 V
		Analog current	0 ... 25 mA
		Digital (voltage mode)	Active high
		Edge Evaluation	Events, reacts on falling or rising edge of the signal
Multifunctional input IDA5V	4	Analog voltage	0 ... 5 V (suitable for example for PT1000 and KTY)
		Programmable pull-up resistor	6.8 kΩ to +5 V
		Digital	Active low
		Edge Evaluation	Events, reacts on falling or rising edge of the signal
		Frequency	0.6 Hz ... 20 kHz
		Incremental encoder interface	Change of position or angular change
		SENT	SENT interface

TECHNICAL DATA

Outputs

Type	Maximal available counts	Possible configuration	Range	Characteristics	Feature
Digital/PWM high side output OPHSP4A	4	PWM	0 ... 4 A	0 ... 100 % duty cycle resolution < 0.1 % PWM frequency 20..500 Hz	<ul style="list-style-type: none"> high side switch precise current measurement, accuracy is 2 % supports current control mode digital feedback, open load detection in OFF state automated shutdown on overcurrent >7.5 A \pm20 % combine several outputs for parallel operation
		Digital	-	ON/OFF	
Main Switch	1	-	-	ON/OFF	<ul style="list-style-type: none"> switches the output group high-side switch Current up to 12 A
Sensor supply voltage 5 V	1	-	5 V	ON/OFF Accuracy voltage output is +2% Accuracy voltage readback is \pm 2.5% \pm 50 mV	Maximal output current 250 mA
Sensor supply voltage 5 ... 12 V	1	Voltage	5 ... 12 V	Accuracy voltage output is \pm 2.5% \pm 50 mV This is valid under the following conditions: <ul style="list-style-type: none"> Capacitive load \leq 470 μF Settling time 100 ms Accuracy voltage readback: \pm 2.5% \pm 50 mV	Maximal output current $I_{MAX} = 250$ mA programmable output needs derating for output voltages $U_{EXT} < 10$ V: $I_{MAX} = 0.875 / (13.5 - U_{EXT})$ A

TECHNICAL DATA

Mechanical Data

Component	Description	Value
Connector	-	Molex CMC 80 pin, mating cycles maximum 20 When 1 Gbit Ethernet is available: 8 pins M12 connector x-coded, mating cycles maximum 50
Indicators	2 LED, dual color (red/green or mixed colors)	1 for the state of the system, 1 freely programmable
Housing	Die-cast aluminum	GORE-TEX™-breathing filter for pressure equalization
Weight	-	about 0.582 kg / about 1.28 lb
Degree of protection (plugged connector)	Variant without M12 Ethernet connector	IP6k7 and IP6k9k
	Variant with M12 Ethernet connector	IP6k7
Dimensions	-	169 mm x 163 mm x 40 mm
Operating temperature, housing temperature	-	-40 ... +85 °C (-40 ... +185 °F)
Operating altitude	-	-400 ... +4000 m

Power Supply

Component	Description	Range	
		Minimum Value	Maximum Value
DC voltage supply	Voltage at +UE ECU supply and +UB power supply	8 V DC	32 V DC
Current consumption	Power supply +UB fully loaded, short-term		12 A
- Standby	Sum of input currents at +UE and +UB ($U_{KL15} = 0$ V, ignition off) Without external load		< 1 mA
- ECU active	+UE supply current ($U_{KL15} > U_{KL15HIGH}$, no external load)		< 400 mA at 8 V supply voltage < 100 mA at 32 V supply voltage

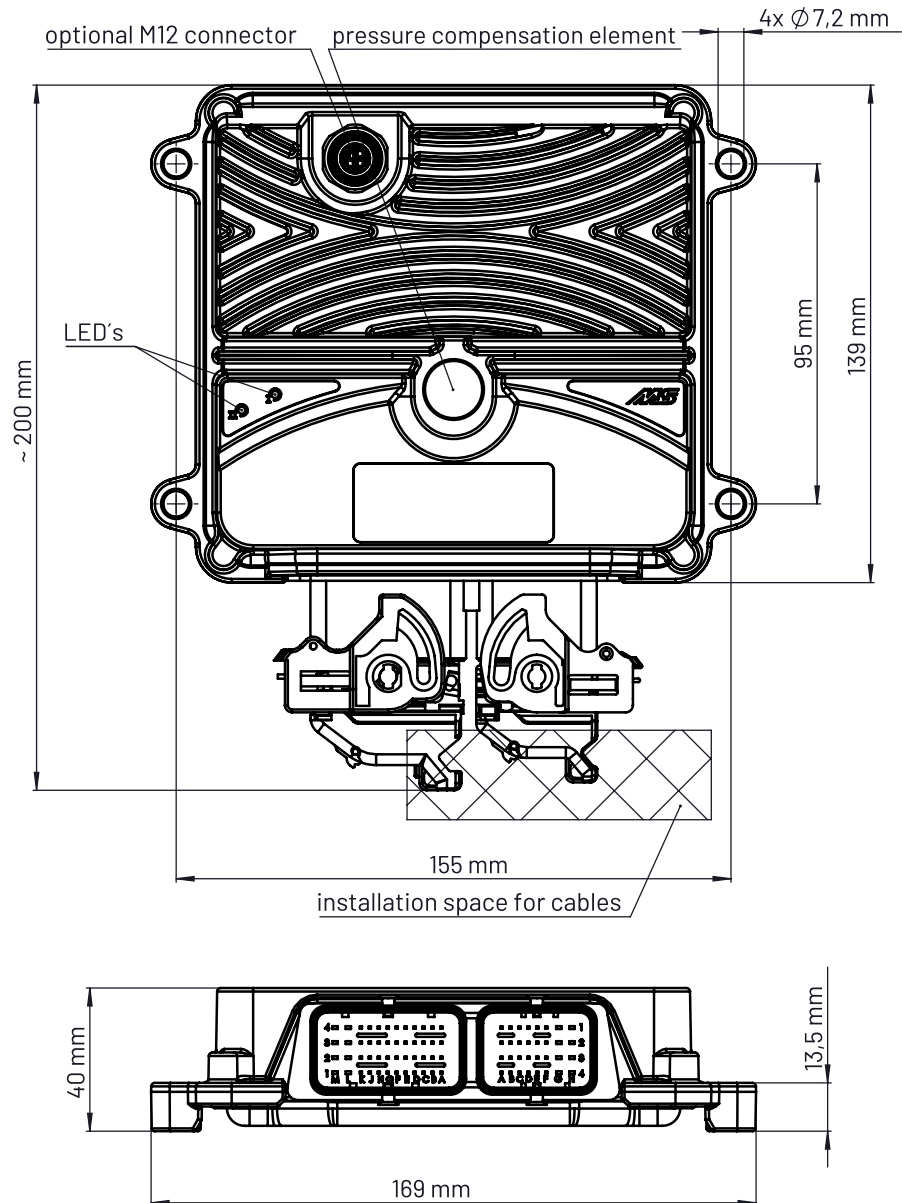

PIN ASSIGNMENT VARIANT 1, 4

Pin Assignment 48 Pin Connector

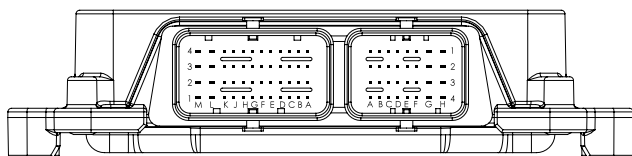

Pin Assignment 48 Pin Connector

Pin No	Functional signal name	Description
48.A1	CAN2_L	CAN bus 2 low
48.A2	CAN2_H	CAN bus 2 high
48.A3	CAN1_L	CAN bus 1 low
48.A4	CAN1_H	CAN bus 1 high
48.B1	LIN_Supply	RS232 TX / LIN (currently not available)
48.B2	LIN	RS232 RX / LIN (currently not available)
48.B3	ETH1_P1_BRR+	BroadR-Reach 100BASE-T1
48.B4	ETH1_P1_BR-R_GND	BroadR-Reach 100BASE-T1
48.C1	ETH1_P3_Rx-	Ethernet 100BASE-TX
48.C2	CAN6_L	CAN bus 6 low
48.C3	ETH1_P1_BRR-	BroadR-Reach 100BASE-T1
48.C4	ETH1_P1_Tx+	Ethernet 100BASE-TX
48.D1	ETH1_P3_Rx+	Ethernet 100BASE-TX
48.D2	CAN6_H	CAN bus 6 high
48.D3	CAN4_GND	CAN bus 4 GND
48.D4	ETH1_P1_Tx-	Ethernet 100BASE-TX
48.E1	ETH1_P3_Tx-	Ethernet 100BASE-TX
48.E2	RS232_Tx	RS232 (Tx/D)

Pin Assignment 48 Pin Connector

Pin No	Functional signal name	Description
48.E3	CAN4_L	CAN bus 4 low
48.E4	ETH1_P1_Rx+	Ethernet 100BASE-TX
48.F1	ETH1_P3_Tx+	Ethernet 100BASE-TX
48.F2	RS232_Rx	RS232 (Rx/D)
48.F3	CAN4_H	CAN bus 4 high
48.F4	ETH1_P1_Rx-	Ethernet 100BASE-TX
48.G1	ETH1_P2_Rx-	Ethernet 10BASE-TX
48.G2	CAN5_L	CAN bus 5 low
48.G3	CAN3_L	CAN bus 3 low
48.G4	ETH2_Rx+	Ethernet 100BASE-TX for diagnosis
48.H1	ETH1_P2_Rx+	Ethernet 10BASE-TX
48.H2	CAN5_H	CAN bus 5 high
48.H3	CAN3_H	CAN bus 3 high
48.H4	ETH2_Rx-	Ethernet 100BASE-TX for diagnosis
48.J1	ETH1_P2_Tx-	Ethernet 10BASE-TX
48.J2	ETH1_P4_Rx-	Ethernet 100BASE-TX
48.J3	ETH1_P4_Tx+	Ethernet 100BASE-TX
48.J4	ETH2_Tx+	Ethernet 100BASE-TX for diagnosis

PIN ASSIGNMENT VARIANT 1, 4

Pin Assignment 48 Pin Connector

Pin No	Functional signal name	Description
48.K1	ETH1_P2_Tx+	Ethernet 10BASE-TX
48.K2	ETH1_P4_Rx+	Ethernet 100BASE-TX
48.K3	ETH1_P4_Tx-	Ethernet 100BASE-TX
48.K4	ETH2_Tx-	Ethernet 100BASE-TX for diagnosis
48.L1	-	Not connected
48.L2	-	Not connected
48.L3	-	Not connected
48.L4	-	Not connected
48.M1	GND	Ground of the ECU
48.M2	+UB	Power Supply outputs
48.M3	+UE	Power Supply ECU
48.M4	KL15	Ignition (KL15)

Pin Assignment 32 Pin Connector

Pin No	Functional signal name	Description
32.A1	CAN1_H	CAN bus 1 high
32.A2	CAN1_L	CAN bus 1 low
32.A3	CAN2_H	CAN bus 2 high
32.A4	CAN2_L	CAN bus 2 low
32.B1	IACV_02	Analog Input IACV
32.B2	IDA35V_04	Multifunctional Input IDA35V
32.B3	IDA5V_01	Multifunctional Input IDA5V
32.B4	Uext_5V	Sensor Supply
32.C1	IDA5V_02	Multifunctional Input IDA5V
32.C2	IACV_01	Analog Input IACV
32.C3	Uext_5-12V	Sensor Supply
32.C4	AGND	Analog ground
32.D1	IDA35V_03	Multifunctional Input IDA35V
32.D2	AGND	Analog ground
32.D3	AGND	Analog ground
32.D4	IACV_04	Analog Input IACV
32.E1	Uext_5-12V	Sensor Supply
32.E2	Uext_5V	Sensor Supply
32.E3	IACV_03	Analog Input IACV
32.E4	IDA5V_03	Multifunctional Input IDA5V

Pin Assignment 32 Pin Connector

Pin No	Functional signal name	Description
32.F1	IDA35V_02	Multifunctional Input IDA35V
32.F2	IDA5V_04	Multifunctional Input IDA5V
32.F3	IDA35V_01	Multifunctional Input IDA35V
32.F4	KL15	Ignition (KL15)
32.G1	OPHSP4A_03	Digital PWM High Side Output OPHSP4A
32.G2	OPHSP4A_04	Digital PWM High Side Output OPHSP4A
32.G3	+UB	Power Supply outputs
32.G4	GND	Ground of the ECU
32.H1	OPHSP4A_01	Digital PWM High Side Output OPHSP4A
32.H2	OPHSP4A_02	Digital PWM High Side Output OPHSP4A
32.H3	+UB	Power Supply outputs
32.H4	+UE	Power Supply ECU

PIN ASSIGNMENT VARIANT 2, 3, 5

Pin Assignment 48 Pin Connector

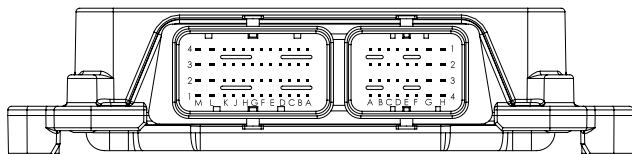

Pin Assignment 48 Pin Connector

Pin No	Functional signal name	Description
48.A1	CAN2_L	CAN bus 2 low
48.A2	CAN2_H	CAN bus 2 high
48.A3	CAN1_L	CAN bus 1 low
48.A4	CAN1_H	CAN bus 1 high
48.B1	LIN_Supply	LIN (currently not available)
48.B2	LIN	LIN (currently not available)
48.B3	ETH1_P1_BRR+	BroadR-Reach 100BASE-T1
48.B4	ETH1_P1_BR-R_GND	BroadR-Reach 100BASE-T1
48.C1	ETH1_P3_Rx-	Ethernet 100BASE-TX
48.C2	CAN6_L	CAN bus 6 low
48.C3	ETH1_P1_BRR-	BroadR-Reach 100BASE-T1
48.C4	ETH1_P1_Tx+	Ethernet 100BASE-TX
48.D1	ETH1_P3_Rx+	Ethernet 100BASE-TX
48.D2	CAN6_H	CAN bus 6 high
48.D3	CAN4_GND	CAN bus 4 GND With variant 3 the pin is isolated
48.D4	ETH1_P1_Tx-	Ethernet 100BASE-TX
48.E1	ETH1_P3_Tx-	Ethernet 100BASE-TX
48.E2	RS232_Tx	RS232 (TxD)
48.E3	CAN4_L	CAN bus 4 low

Pin Assignment 48 Pin Connector

Pin No	Functional signal name	Description
		With variant 3 the pin is isolated
48.E4	ETH1_P1_Rx+	Ethernet 100BASE-TX
48.F1	ETH1_P3_Tx+	Ethernet 100BASE-TX
48.F2	RS232_Rx	RS232 (RxD)
48.F3	CAN4_H	CAN bus 4 high With variant 3 the pin is isolated
48.F4	ETH1_P1_Rx-	Ethernet 100BASE-TX
48.G1	ETH1_P2_Rx-	Ethernet 10BASE-TX
48.G2	CAN5_L	CAN bus 5 low
48.G3	CAN3_L	CAN bus 3 low
48.G4	ETH2_Rx+	Ethernet 100BASE-TX for diagnosis
48.H1	ETH1_P2_Rx+	Ethernet 10BASE-TX
48.H2	CAN5_H	CAN bus 5 high
48.H3	CAN3_H	CAN bus 3 high
48.H4	ETH2_Rx-	Ethernet 100BASE-TX for diagnosis
48.J1	ETH1_P2_Tx-	Ethernet 10BASE-TX
48.J2	-	Not connected
48.J3	-	Not connected
48.J4	ETH2_Tx+	Ethernet 100BASE-TX for diagnosis

PIN ASSIGNMENT VARIANT 2, 3, 5

Pin Assignment 48 Pin Connector

Pin No	Functional signal name	Description
48.K1	ETH1_P2_Tx+	Ethernet 10BASE-TX
48.K2	-	Not connected
48.K3	-	Not connected
48.K4	ETH2_Tx-	Ethernet 100BASE-TX for diagnosis
48.L1	-	Not connected
48.L2	-	Not connected
48.L3	-	Not connected
48.L4	-	Not connected
48.M1	GND	Ground of the ECU
48.M2	+UB	Power Supply outputs
48.M3	+UE	Power Supply ECU
48.M4	KL15	Ignition (KL15)

Pin Assignment 32 Pin Connector

Pin No	Functional signal name	Description
32.A1	CAN1_H	CAN bus 1 high
32.A2	CAN1_L	CAN bus 1 low
32.A3	CAN2_H	CAN bus 2 high
32.A4	CAN2_L	CAN bus 2 low
32.B1	IACV_02	Analog Input IACV
32.B2	IDA35V_04	Multifunctional Input IDA35V
32.B3	IDA5V_01	Multifunctional Input IDA5V
32.B4	Uext_5V	Sensor Supply
32.C1	IDA5V_02	Multifunctional Input IDA5V
32.C2	IACV_01	Analog Input IACV
32.C3	Uext_5-12V	Sensor Supply
32.C4	AGND	Analog ground
32.D1	IDA35V_03	Multifunctional Input IDA35V
32.D2	AGND	Analog ground
32.D3	AGND	Analog ground
32.D4	IACV_04	Analog Input IACV
32.E1	Uext_5-12V	Sensor Supply
32.E2	Uext_5V	Sensor Supply
32.E3	IACV_03	Analog Input IACV
32.E4	IDA5V_03	Multifunctional Input IDA5V

Pin Assignment 32 Pin Connector

Pin No	Functional signal name	Description
32.F1	IDA35V_02	Multifunctional Input IDA35V
32.F2	IDA5V_04	Multifunctional Input IDA5V
32.F3	IDA35V_01	Multifunctional Input IDA35V
32.F4	KL15	Ignition (KL15)
32.G1	OPHSP4A_03	Digital PWM High Side Output OPHSP4A
32.G2	OPHSP4A_04	Digital PWM High Side Output OPHSP4A
32.G3	+UB	Power Supply outputs
32.G4	GND	Ground of the ECU
32.H1	OPHSP4A_01	Digital PWM High Side Output OPHSP4A
32.H2	OPHSP4A_02	Digital PWM High Side Output OPHSP4A
32.H3	+UB	Power Supply outputs
32.H4	+UE	Power Supply ECU

PIN ASSIGNMENT VARIANT 2, 3, 5

Pin Assignment 8 Pin M12 Connector

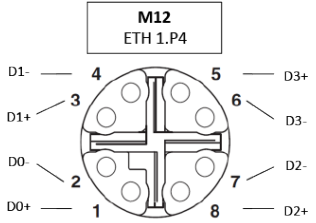

Pin No	Functional signal name	BIOS define
1	ETH1_P4_D0+	X_ETH_SWLETH1_PORT4
2	ETH1_P4_D0-	
3	ETH1_P4_D1+	
4	ETH1_P4_D1-	
5	ETH1_P4_D3+	
6	ETH1_P4_D3-	
7	ETH1_P4_D2-	
8	ETH1_P4_D2+	

QUALIFICATION

Compliance Information

Standard	Description	Parameter
ISO/IEC 17050-1	 Conformity	See Declaration of Conformity
EN ISO 13849-1:2015	Safety of machinery	PL d / Cat. 2
IEC 61508:2010	Functional safety	SIL 2
KBA (Kraft-fahrt-Bundesamt)	<p>Certification</p> <p>This approved device can be used on any vehicle type with the following restrictions:</p> <p>All vehicle types with a 12 V respectively 24 V - electrical wiring and battery(-) at the body</p>	According UN ECE Regulation No. 10
2011/65/EU 2015/863/EU	RoHS	Restriction of Hazardous Substances
2006/42/EC	Machinery directive	

DETAILED QUALIFICATION

CE - EN IEC 61000-6-2:2019

Standard	Test	Parameter
EN IEC 61000-6-2:2019	Immunity for industrial environments	-
	DIN EN 61000-4-2 Electrostatic discharge immunity test - direct discharges	330 Ω / 150 pF, Contact discharge ± 4 kV Air discharge ± 8 kV
	DIN EN 61000-4-2 Electrostatic discharge immunity test - indirect discharges (HCP, VCP)	330 Ω / 150 pF, Contact discharge ± 4 kV
	DIN EN 61000-4-3 Radiated, radio-frequency, electromagnetic field immunity test	80 MHz to 1000 MHz -> 10V/m; 1.4 GHz to 6.0 GHz -> 3V/m; horizontal and vertical
	DIN EN 61000-4-4 Burst - supply lines (Electrical fast transient / burst immunity test)	± 1 kV, 5/50 ns tr/th, repetition frequency 5kHz or 100kHz
	DIN EN 61000-4-4 Burst - data lines (Electrical fast transient / burst immunity test)	± 1 kV, 5/50 ns tr/th, repetition frequency 5kHz or 100kHz
	DIN EN 61000-4-5 Surge - supply lines (immunity test)	unsymmetrisch: ± 1 kV symmetrisch: ± 0,5 kV
	DIN EN 61000-4-5 Surge - data lines (immunity test)	unsymmetrisch: ± 1 kV
	DIN EN 61000-4-6 Conducted immunity - supply lines (Immunity to conducted distur-	150 kHz to 80 MHz, 10V

DETAILED QUALIFICATION

CE - EN IEC 61000-6-2:2019

Standard	Test	Parameter
	bances, induced by radio-frequency fields)	
DIN EN 61000-4-6	Conducted immunity - data lines (Immunity to conducted disturbances, induced by radio-frequency fields)	150 kHz to 80 MHz, 10V
DIN EN 61000-4-8	magnetic field	50, 60 Hz, 30A/m
EN 61000-6-4:2007 + A1:2011	Emission standard for industrial environments	Conducted (CE) 0.15 MHz....30 MHz Radiated (RE) 30 MHz ... 1000 MHz (6000MHz) 10m

Functional Safety - DIN EN 61326-3-1

Standard	Test	Parameter
DIN EN 61326-3-1:2018	Tabelle 2 DIN EN 61000-4-2 - direct discharges Electrostatic discharge immunity test	330 Ω / 150 pF, Contact discharge ± 6 kV Air discharge ± 8 kV
	Tabelle 2 DIN EN 61000-4-2 - indirect discharges Electrostatic discharge immunity test	330 Ω / 150 pF, Contact discharge ± 6 kV
	Tabelle 2 DIN EN 61000-4-3 Radiated, radio-frequency, electro-magnetic field immunity test	80 MHz to 1000 MHz, 20V/m; 1,4 GHz to 2 GHz, 10V/m 2,0 GHz to 2,7 GHz -> 3V/m; horizontal, vertical
	Tabelle 2 DIN EN 61000-4-8 magnetic field	30 A/m (No higher test levels will be applied)
	Tabelle 4 DIN EN 61000-4-4 Burst - supply lines (Electrical fast transient / burst immunity test)	± 3 kV, 5/50 ns tr/th, repetition frequency 5kHz
	Tabelle 5 DIN EN 61000-4-4 Burst - data lines (Electrical fast transient / burst immunity test)	± 2kV, 5/50 ns tr/th, repetition frequency 5kHz
	Tabelle 4 DIN EN 61000-4-5 Surge - supply lines (immunity test)	unsymmetrisch: '± 2 kV symmetrisch: '± 1 kV
	Tabelle 5 DIN EN 61000-4-5	unsymmetrisch: '± 2 kV

DETAILED QUALIFICATION

Functional Safety - DIN EN 61326-3-1

Standard	Test	Parameter
	Surge - data lines (immunity test)	
Tabelle 4 DIN EN 61000-4-6	Conducted immunity - supply lines (Immunity to conducted disturbances, induced by radio-frequency fields)	150 kHz to 80 MHz, 10V
Tabelle 5 DIN EN 61000-4-6	Conducted immunity - data lines (Immunity to conducted disturbances, induced by radio-frequency fields)	150 kHz to 80 MHz, 10V
Tabelle 4 IEC 61000-4-16	Conducted common-mode voltages Supply lines	1 V to 10 V, 20 dB/Decade (1,5 kHz to 15 kHz) 10 V (15 kHz to 150 kHz) 10 V (constant with direct current, 16 ² / ₃ Hz, 50 / 60 Hz and 150 / 180 Hz) 100 V short period (1 s, with direct current, 16 ² / ₃ Hz and 50 / 60 Hz)
Tabelle 5 IEC 61000-4-16	Conducted common-mode voltages signal lines	1 V to 10 V, 20 dB/Decade (1,5 kHz to 15 kHz) 10 V (15 kHz to 150 kHz) 10 V (constant with direct current, 16 ² / ₃ Hz, 50 / 60 Hz and 150 / 180 Hz) 100 V short period (1 s, with direct current, 16 ² / ₃ Hz and 50 / 60 Hz)

Functional Safety - DIN EN 61326-3-1

Standard	Test	Parameter
	Tabelle 4 IEC 61000-4-29 Votlage dips (Supply lines)	40 % U _T during 10 ms
	Tabelle 4 IEC 61000-4-29 Short interruptions (Supply lines)	0 % U _T during 20 ms

E1 - ECE R10

Note

E1 conformity is fulfilled as long as no "Immunity related functions" are controlled via the Ethernet channels, which are not connected via M12 connector, in the sense of ECE-R10 chapter 2.12.

DETAILED QUALIFICATION

E1 - ECE R10

Standard	Test	Parameter
UN ECE R10 Add. 9, Rev. 6 Annex 7	Radiated broadband emissions from ESAs CISPR25:2004	30 MHz ... 1000MHz
UN ECE R10 Add. 9, Rev. 6 Annex 8	Radiated narrowband emissions from ESAs CISPR25:2004	30 MHz ... 1000MHz
UN ECE R10 Add. 9, Rev. 6 Annex 9	Immunity of ESAs to electromagnetic radiation General: ISO 11452-1:2005 ALSE: ISO 11452-2:2004 BCI: ISO 11452-4:2011 (Stripline and TEM alternative test methods)	General 20MHz ... 2000MHz 20 MHz ... 800MHz: AM 800 MHz ... 2000 MHz: PM BCI: 20 MHz ... 400 MHz, 60mA (substitution (150mm) or closed loop (900mm) method allowed) Antenne, ALS E (vert): 200 MHz ... 800 MHz, 30 V/m, AM 800 MHz ... 2000 MHz, 30 V/ m, PM
UN ECE R10 Add. 9, Rev. 6 Annex 10	Conducted transient emission from ESAs on 12 V supply lines ISO 7637-2:2004	slow/fast: pos: +75 V neg: -100V
	Conducted transient emission from ESAs on 24V supply lines ISO 7637-2:2004	slow/fast: pos: +150 V neg: -450V
	Electrical transient conduction along supply lines	Pulse 1 - 75V, 5000 pulses t1 = 0,5s to 5s

E1 - ECE R10

Standard	Test	Parameter
	12V System, Level 3 ISO 7637-2:2004	Pulse 2a 37V, 5000 pulses t1 = 0,2s to 5s
		Pulse 2b 10V, 10 pulses td = 0,2s to 2s
		Pulse 3a -112V, 1hr
		Pulse 3b 75V, 1hr
		Pulse 4 Us = -6V Ua = -2,5V to -6V 1 pulse
	Electrical transient conduction along supply lines 24V System, Level 3 ISO 7637-2:2004	Pulse 1 - 450V, 5000 pulses t1 = 0,5s to 5s
		Pulse 2a 37V, 5000 pulses t1 = 0,2s to 2s
		Pulse 2b 20V, 10 pulses td = 0,2s to 2s
		Pulse 3a -150V, 1hr
		Pulse 3b +150V, 1hr

DETAILED QUALIFICATION

E1 - ECE R10

Standard	Test	Parameter
		Pulse 4 $U_s = -12V$ $U_a = -5V$ to $-12V$ 1 pulse

Electrical Safety

Standard	Test	Parameter
ISO 16750-2:2012-11	Direct current supply voltage	Operation at T_{max} with maximum and minimum voltage Operation at T_{min} with maximum and minimum voltage
	Overvoltage - Systems with 12 V / 24 V nominal voltage - 12 V Systems	18 V for 60 min. at 20 °C below T_{max} 24 V for 60 s at room temperature
	Overvoltage - Systems with 12 V / 24 V nominal voltage - 24 V Systems	36 V for 60 min. at 20 °C below T_{max}
	Superimposed alternating voltage - 12 V Systems	$U_{smax} = 16 V$ (for $U_N = 12 V$) Sweep duration: 120 seconds Number of sweeps: 5 Severity 1, 2, 4
	Superimposed alternating voltage - 24 V Systems	$U_{smax} = 32 V$ (for $U_N = 24 V$) Sweep duration: 120 seconds Number of sweeps: 5 Severity 1, 2, 3
	Slow decrease and increase of supply voltage	Decrease supply voltage from U_{smin} to 0 V and increase it from 0 V to U_{smin} . Applying a change rate of $(0.5 \pm 0.1) V$ per minute

DETAILED QUALIFICATION

Electrical Safety

Standard	Test	Parameter
	Discontinuities in supply voltage - Momentary drop in supply voltage - 12 V Systems	Drop to 4.5 V for ≤ 100 ms
	Discontinuities in supply voltage - Momentary drop in supply voltage - 24 V Systems	Drop to 9 V for ≤ 100 ms
	Discontinuities in supply voltage - Reset behavior voltage drop	Decrease supply voltage from U_{smin} in 5 % steps
	Discontinuities in supply voltage - Starting profile 12 V code C	Voltage cranking; Level 1
		Voltage cranking; Level 2
		Voltage cranking; Level 3
		Voltage cranking; Level 4
	Discontinuities in supply voltage - Starting profile 24 V code E	Voltage cranking; Level 1
		Voltage cranking; Level 2
		Voltage cranking; Level 3
	Discontinuities in supply voltage-Load Dump - Pulse B - 12 V System	with centralized load dump suppression 5 Pulses
	Discontinuities in supply voltage-Load Dump - Pulse B - 24 V System	with centralized load dump suppression 5 Pulses
	Reversed voltage - Case 1 - 12 V Systems	Unom. = 12 V -> Case 1 - Test Voltage = - 4 V reversed polarity Duration: 60 s

Electrical Safety

Standard	Test	Parameter
	Reversed voltage - Case 2 - 12 V Systems	Unom. = 12 V -> Case 2 - Test Voltage = - 14 V reversed polarity Duration: 60 s
	Reversed voltage - Case 2 - 24 V Systems	Unom. = 24 V -> Case 2 - Test Voltage = 28 V reversed polarity Duration: 60 s
	Ground reference and supply offset - 12 V Systems	± 1 V offset; only required if two or more power supplies exist; Low-Side-Sensor must be connected to ground point at ECU connector
	Ground reference and supply offset - 24 V Systems	± 1 V offset; only required if two or more power supplies exist; Low-Side-Sensor must be connected to ground point at ECU connector
	Open circuit tests - Single line interruption - 12 V Systems	Interruption of each single Output for (10 ± 1) s.
	Open circuit tests - Single line interruption - 24 V Systems	Interruption of each single Output for (10 ± 1) s.
	Open circuit tests - Multiple line interruption - 12 V Systems	Disconnect the DUT for (10 ± 1) s.
	Open circuit tests - Multiple line interruption - 24 V Systems	Disconnect the DUT for (10 ± 1) s.

DETAILED QUALIFICATION

Electrical Safety

Standard	Test	Parameter
	Short circuit protection - signal circuits	Connect every In- and Output to maximum supply voltage (Usmax) and Ground for 1 minute various modes necessary
	Short circuit protection - load circuits (supply lines)	to load circuits

Electromagnetic Compatibility (E1)

Standard	Test	Parameter
ISO 7637-2: 2011	Conducted transient emission from ESAs on 12 V supply lines, Level 3 ISO 7637-2:2011	slow+: +37 V slow-: -75 V fast+: +75 V fast-: -112 V
	Conducted transient emission from ESAs on 24 V supply lines, Level 3 ISO 7637-2:2011	slow+: +37 V slow-: -150 V fast+: +150 V fast-: -150 V
	Electrical transient conduction along supply lines - 24 V System, Level 4	Pulse 1 -600 V, 500 pulses t1 ≥ 0,5 s
		Pulse 2a +112 V, 500 pulses t1 = 0,2 s to 5 s
		Pulse 2b +20 V, 10 pulses td = 0,2 s to 2 s
		Pulse 3a -300 V, 1 h
		Pulse 3b +300 V, 1 h

DETAILED QUALIFICATION

Environmental Qualification

Standard	Test	Parameter
DIN EN 50102:1997-09	Degrees of protection provided by enclosures for electrical equipment against external mechanical impacts (IK code).	IK7 Impact energy (joules): 2
ISO 4892-2:2013-06	Exposure from Xenon-arc lamps	Method A - Testing with filters for global radiation - Cycle no. 1, table 3
ISO 16750-3:2012	Resonance search	10Hz - 2000Hz, 1g, 0,5oct/min
	Test VII - Commercial vehicle, sprung masses	Vibration noise with temperature superimposition in case of natural frequencies of DUT upper 30Hz: random vibration acc IEC60068-2-64 from 10 Hz to 2000 Hz for 32 hrs each axis, Temperature cycle 8h from Tmin to Tmax
	Test VII - Commercial vehicle, sprung masses, Additional profile in the case of DUT natural frequencies < 30 Hz (Test VII)	random vibration acc IEC60068-2-64 from 10 Hz to 45 Hz for 32 hrs each axis, Temperature cycle 8 h from Tmin to Tmax
	Mechanical Shock - Test for devices on rigid points on the body and on the frame	in acc. IEC 60068-2-27 half-sinusoidal Acceleration 500 m/s ² Duration 6 ms room temperature 10 shocks per test direction
	Free fall (parts that may withstand falling without damages)	3 devices, 2 falls every device on the opposite side of the housing. drop height: 1 m to concrete ground or steel plate

Environmental Qualification

Standard	Test	Parameter
ISO 16750-4:2010	Tests at constant temperature: Low temperature - storage	- 40°C for 24 hrs
	Tests at constant temperature: Low temperature - operation	Tmin for 24 hrs
	Tests at constant temperature: High temperature - storage	85°C for 48 hrs
	Tests at constant temperature: High temperature - operation	Tmax for 96 hrs
	Temperature step test	20°C to Tmin to Tmax, 5°C steps; *Perform functional tests (OM 3.2) when DUT has reached the new temperature with Usmin and Usmax
	Temperature cycling test	acc. to IEC 60068-2-14, Test Nb 30 cycles á 480 min , Tmin to Tmax Duration: 10 days *OM 3.2 for phases with electrical operation
	Temperature cycling test - Rapid change of Temperature	acc. to IEC 60068-2-14, Test Na Transfer time ≤ 30 sec.
	Ice water shock test - Splash water test	Heat the DUT at Tmax for the specified holding time t _n , then splash it with ice water (0 °C to +4 °C) for 3 sec.; (t _n = 1 hr or until temp. Stabilization is reached) 100 cycles each 66 Min.

DETAILED QUALIFICATION

Environmental Qualification

Standard	Test	Parameter
	Salt spray test - Corrosion test	acc to IEC60068-2-52, Test Kb Severity: Severity 4 Cycle duration: 7 days Number of cycles: 2 cycles
	Salt spray test - Leakage and function	acc. to IEC60068-2-11, Test Ka Cycle duration: 24 hrs (8 hrs salt spray - 16hrs without spray) Number of cycles: 6 cycles
	Humid heat cyclic - Test 2: Composite temperature / humidity cyclic test	acc. to IEC60068-2-38, -Z/AD 10 cycles, upper temperture +65°C 93% r.H. 5 cycles with frost phase (-10°C); Duration: 11 days *OM 3.2 when the maximum cycle temperature is reached;
	Humid head cyclic - Test 3: Dewing test	In acc. To IEC 60068-2-38, Test Db Upper Temp.: 80°C, 5 cycles
	Damp heat, steady-state test	acc. to IEC60068-2-78; +40°C and 85% r.H. OM: 2.1 for 20 days 23 hrs OM: 3.2 for the last hour Duration: 21 days
	Corrosion test with flow of mixed gas	acc. to IEC60068-2-60, Test Ke, Method 4 Test cycle: 21 days in pollutant gas atmosphere (SO2, H2S, NO2, Cl2)
	Solar radiation	Confirmation of housing- and plug manufacturer about UV and OZON durability or test e.g. ISO 75220 or DIN EN 60068-2-5

Environmental Qualification

Standard	Test	Parameter
	Dust Test	acc. to ISO 20653 Cycle duration: 20 min. Number of cycles: 20 cycles
	Protection against dust and water	ISO 20653
ISO 16750-5	Chemical resistance	Exposure time 24 h, Exposure condition 20 °C, 85 % relative humidity, Gasoline, Methanol, Battery acid, Protective lacquer, Windshield washer fluid, Vehicle washing chemicals, Cold cleaning agent, Cleaning solvent, Denatured alcohol, Runway de-icer, Aceton Exposure time 24 h Exposure condition 125 °C, 85 % relative humidity Diesel fuel, Diesel fuel "Bio", Engine oil, Transmission fluid, Automatic transmission oil, Hydraulic oil, Greasees, Silicone oil, Brake fluid, Antifreeze fluid, Urea, Protective lacquer remover, Contact spray
ISO 20653:2013-02	IP Protection	IP6k6k, IPx7, IPx9k